

AIR CONDITIONING TECHNICAL HANDBOOK

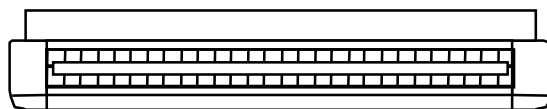

A Selection of Useful Information
For Single/Twin Split, Super Multi, Modular Multi
Super Modular Multi, Mini SMMS, Super Heat Recovery,
Digital Inverter Models and Super Digital Inverter.

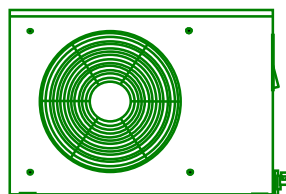
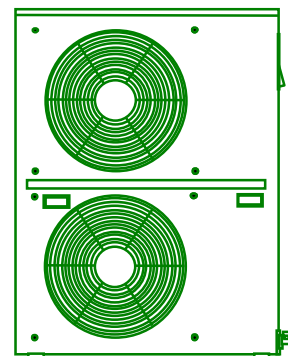
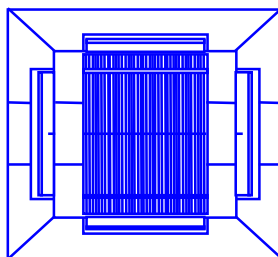
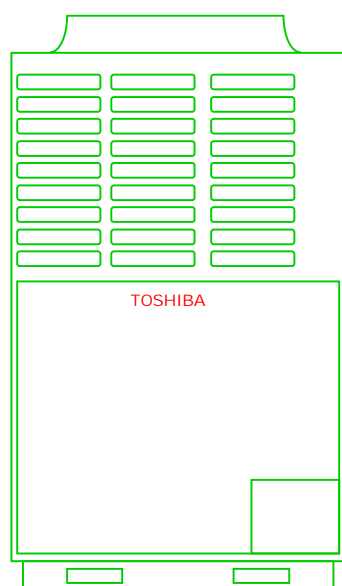

24 Hour Technical Helpline: 0870 843 0333

Make Up Of Model Number

RAV Products

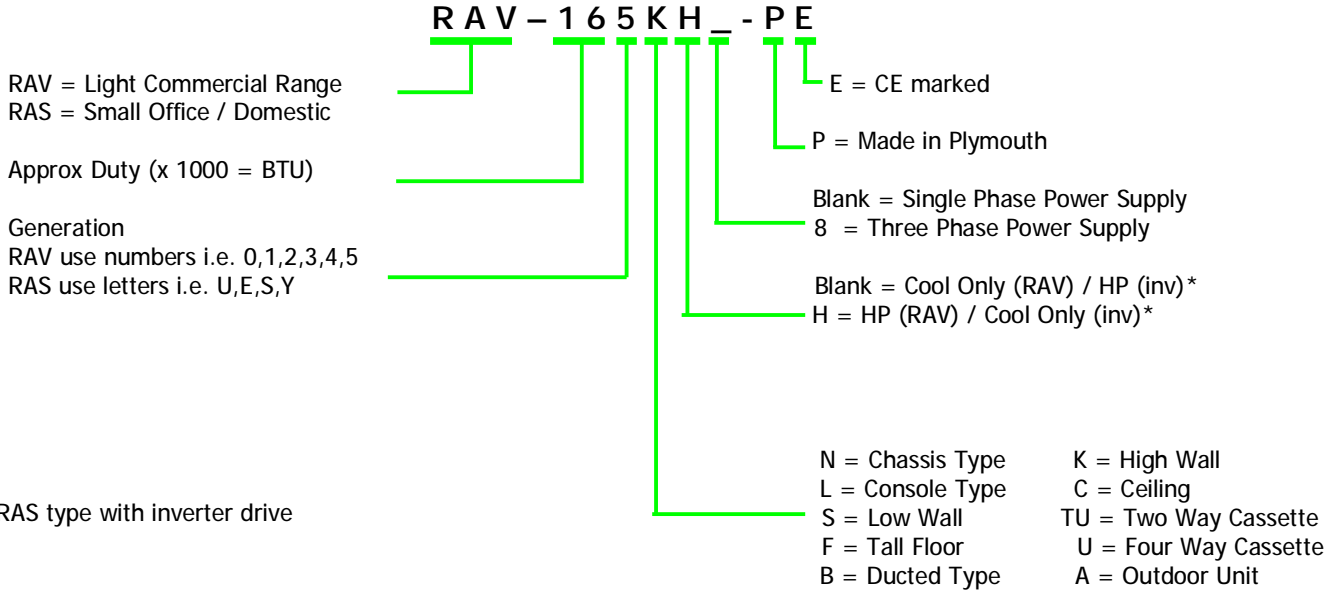

Digital Inverter

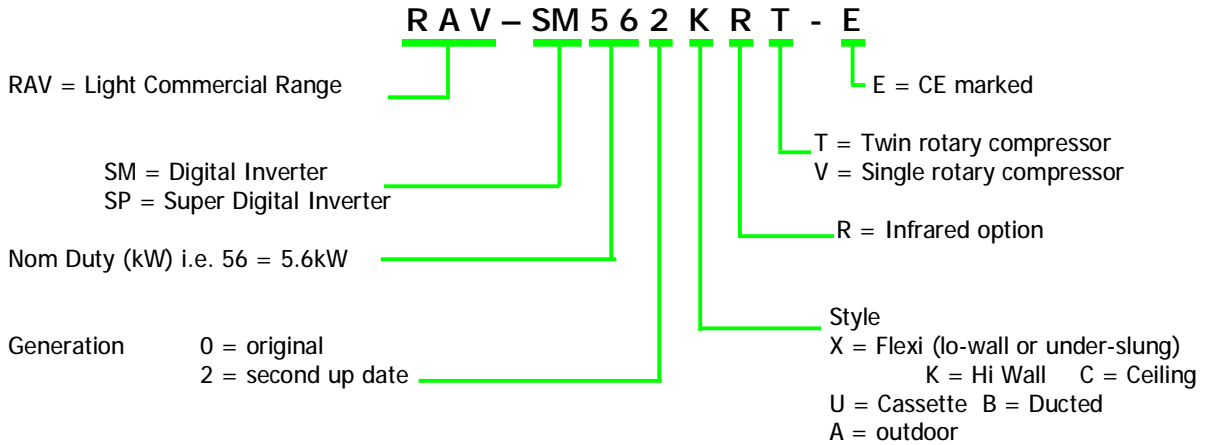

Modular Multi Outdoor Units

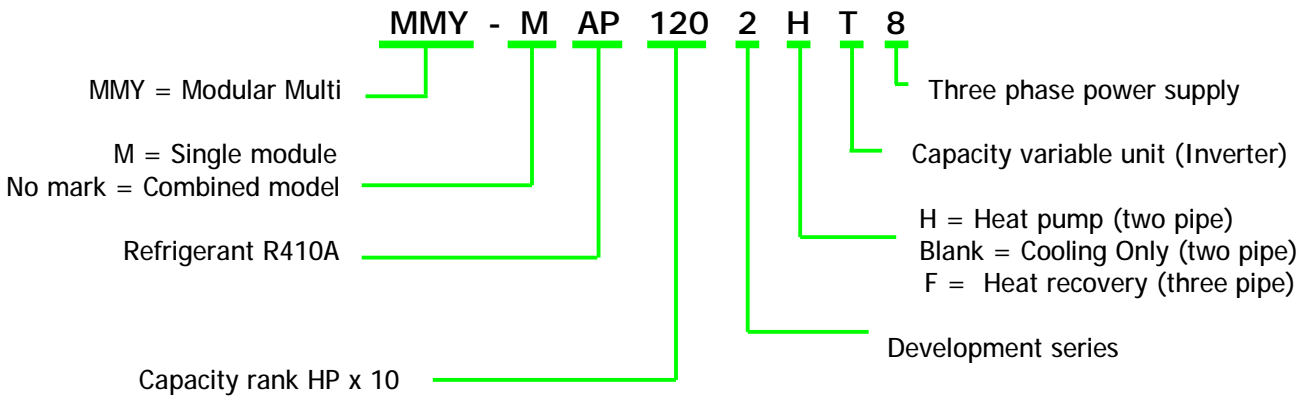

Modular Multi Indoor Units

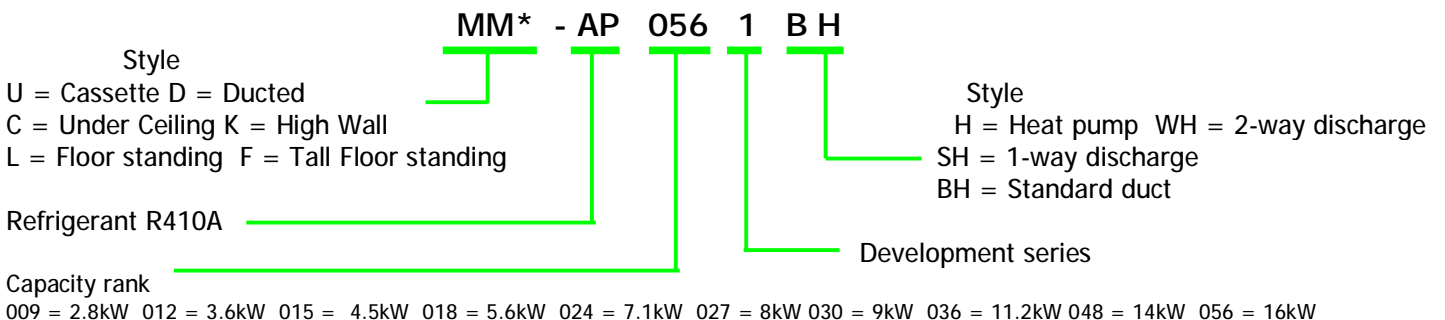

Index

Model number make up	page 2
Technical Specifications single splits	page 4
Twin, multi splits & VRF Elect & Ref specs	page 5
Additional refrigerant SMMS, Mini SMMS, SHRM	page 5 / 6
VRF system makeup chart	page 6
RAS-Multi Combinations / Elect & Ref specs	page 7 / 8
RAS Auto Restart set up	page 8
Acoustic Data	page 9
AI Group / Zone Network layouts	page 10
AI Central Controller – Zone Address	page 11
RAV Heat Pump twin split specs (R407c 7 R410A)	page 12 / 13
16:1 Interface, wiring and piping details	page 14
16:1 Interface, additional charge calculations	page 15
PCB features – Indoor R407c heat pump	page 16
PCB features – Indoor R22 heat pump & cool only	page 17
PCB features – Outdoor Unit, emergency operation	page 18
PCB features – Outdoor Unit, LED information	page 19
Printed Circuit Boards by type number	page 20 / 21
Outdoor Unit Fan Motors	page 22 / 23
Single Phase Compressors – listed	page 24
Three Phase Compressors – listed	page 25
Single Phase units with Three Phase Compressors – Listed	page 26
Split System Return Air Filters	page 26
RAS Fault Codes	page 28 / 29
RAV Fault Codes	page 30
2-Pipe Fault Codes	page 31
3-pipe Fault Codes	page 32
SMI Fault Codes	page 33
Modular Multi Fault Codes	page 34 / 35
RAV-SM RAV-SP Fault Codes	page 36
SMMS / SHRM Fault Codes	page 37 / 39
SMMS / SHRM Data Display	page 40
SMMS / SHRM Switch Positions	page 41
Modular Multi Switch Positions	page 42
Modular Multi Control Set-Up	page 43
Manual Operation of Pulse Motor Valve (SM & SMI)	page 44
Digital Inverter Controller Guidelines	page 45 / 47
TCC net Central Controller configuration	page 48 / 53
TCC net central controller wiring examples	page 54 / 56
Digital Inverter Configuration menu	page 57 / 58
TCC net Control Options	page 59
Assorted wiring diagrams for auxiliary devices	page 61 / 63
Common Sensor Characteristics	page 64
New Harmonised Electrical Wiring Colours	page 65 / 66
Technical Support	page 67 / 68
Notes	page 69

Technical Specifications - Single Splits

Model	Duty kW	Pipe Sizes		Max Run m	Prechg m	Add Chg g/m	Phase	Power to	N° Cores +Gnd	Amps St/Rn	Refrig
		Liq.	Suct.								
Cooling Only											
RAS-10UA-ES3	2.7	1/4	3/8	10	10	n/a	Single	Indoor	2	16/3.7	R410A
RAS-13UA-ES3	3.75	1/4	1/2	15	15	n/a	Single	Indoor	2	24/5.7	R410A
RAS-18UA-ES3	5.1	1/4	1/2	20	15	20	Single	Outdoor	3	47/7.8	R410A
RAS-24UA-ES3	6.45	1/4	1/2	20	15	20	Single	Outdoor	3	54/10.8	R410A
Heat Pumps											
RAS-10UAH-ES4	2.7	1/4	3/8	10	10	n/a	Single	Indoor	4	19/4.5	R410A
RAS-13UAH-ES4	3.5	1/4	1/2	15	15	n/a	Single	Indoor	4	25/5.6	R410A
RAS-18UAH-ES4	5.1	1/4	1/2	20	15	20	Single	Outdoor	4	47/8	R410A
RAS-24UAH-ES4	6.45	1/4	1/2	20	15	20	Single	Outdoor	4	54/11.2	R410A
RAS-10UAV-E3	0.9-3.0	1/4	3/8	10	10	N/a	Single	Outdoor	3	4.6/4.4	R410A
RAS-13UAV-E3	0.9-4.0	1/4	3/8	15	15	n/a	Single	Outdoor	3	7.2/7	R410A
RAS-10NAV-E	0.9-3.0	1/4	3/8	10	10	n/a	Single	Outdoor	3	3.8 / 3.4	R410A
RAS-13NAV-E	0.9-4.0	1/4	3/8	15	15	n/a	Single	Outdoor	3	5.3 / 4.8	R410A
RAS-16NAV-E	0.9-5.2	1/4	1/2	15	15	n/a	Single	Outdoor	3	8.0 / 7.2	R410A
RAS-10JAVP-E	0.6-3.4	1/4	3/8	25	15	20	Single	Outdoor	3	*/3.29	R410A
RAS-13JAVP-E	0.6-4.2	1/4	3/8	25	15	20	Single	Outdoor	3	*/4.78	R410A
RAS-10EAVP-E	0.5-3.5	1/4	3/8	25	15	20	Single	Outdoor	3	*/ 2.3	R410A
RAS-13EAVP-E	0.6-4.5	1/4	3/8	25	15	20	Single	Outdoor	3	* / 3.9	R410A
RAS-16EAVP-E	0.8-5.0	1/4	1/2	25	15	20	Single	Outdoor	3	* / 5.9	R410A
RAV-SM560AT-E	1.5 - 5.6	1/4	1/2	30	20	20	Single	Outdoor	3	*/8.42	R410A
RAV-SM800AT-E	2.2 - 8.0	3/8	5/8	50	20	40	Single	Outdoor	3	*/11.32	R410A
RAV-SM1100AT-E	2.2 - 11.0	3/8	5/8	50	20	40	Single	Outdoor	3	*/16.3	R410A
RAV-SM1400AT-E	3.0 - 14.0	3/8	5/8	50	20	40	Single	Outdoor	3	*/19.2	R410A
RAV-SM561 AT-E	1.5 - 5.6	1/4	1/2	30	20	20	Single	Outdoor	3	*/7.7 /	R410A
RAV-SM562 AT-E	1.5 - 5.6	1/4	1/2	30 min 5	20	20	Single	Outdoor	3	*/ 8.42	R410A
RAV-SM801 AT-E	2.2 - 8.0	3/8	5/8	30	20	40	Single	Outdoor	3	*/10.3	R410A
RAV-SM802 AT-E	2.2 - 8.0	3/8	5/8	30 min 5	20	40	Single	Outdoor	3	*/ 11.32	R410A
RAV-SM1101 AT-E	2.2 - 11.2	3/8	5/8	50	20	40	Single	Outdoor	3	*/15.0	R410A
RAV-SM1102 AT-E	2.2 - 11.2	3/8	5/8	50 min 5	30	40	Single	Outdoor	3	*/16.30	R410A
RAV-SM1401 AT-E	3.0 - 14.0	3/8	5/8	50	20	40	Single	Outdoor	3	*/17.6	R410A
RAV-SM1402 AT-E	3.0 - 14.0	3/8	5/8	50 min 5	30	40	Single	Outdoor	3	*/19.20	R410A
RAV-SP560AT-E	1.5 - 5.6	1/4	1/2	50	20	20	Single	Outdoor	3	*/6.6	R410A
RAV-SP562AT-E	1.5 - 5.6	1/4	1/2	50 min 5	20	20	Single	Outdoor	3	*/7.17	R410A
RAV-SP800AT-E	2.2 - 8.0	3/8	5/8	50	20	40	Single	Outdoor	3	*/8.2	R410A
RAV-SP802AT-E	2.2 - 8.0	3/8	5/8	50 min 5	30	40	Single	Outdoor	3	*/8.95	R410A
RAV-SP1100AT-E	2.2 - 11.2	3/8	5/8	70	20	40	Single	Outdoor	3	*/10.3	R410A
RAV-SP1102AT-E	2.2 - 11.2	3/8	5/8	70 min 5	30	40	Single	Outdoor	3	*/11.24	R410A
RAV-SP1400AT-E	3.0 - 13.2	3/8	5/8	70	20	40	Single	Outdoor	3	*/15.1	R410A
RAV-SP1402AT-E	3.0 - 14.0	3/8	5/8	70 min 5	30	40	Single	Outdoor	3	*/16.54	R410A

* Inverter units no initial start current

Twin & Multi Splits

Electrical Details

Model (Outdoor)	Model (Indoor x 2)	Phase	Power To	Start Amps	Run Amps	N° Cores + Gnd
Twin Splits						
RAV-SM1101 AT-E	RAV-SM561*T-E	Single	Outdoor	*	15.0	3
RAV-SM1102 AT-E	RAV-SM562*T-E	Single	Outdoor	*	16.3	3
RAV-SM1401 AT-E	RAV-SM801*T-E	Single	Outdoor	*	17.6	3
RAV-SM1402 AT-E	RAV-SM802*T-E	Single	Outdoor	*	19.2	3
Multi Splits						
RAV-SP1100AT-E	RAV-SM561*T-E	Single	Outdoor	*	10.3	3
RAV-SP1102AT-E	RAV-SM562*T-E	Single	Outdoor	*	11.24	3
RAV-SP1400AT-E	RAV-SM801*T-E	Single	Outdoor	*	15.1	3
RAV-SP1402AT-E	RAV-SM802*T-E	Single	Outdoor	*	16.51	3
Cooling Only VRF (SMMS)						
MMY-MAP0501T8	N/A	Three	Outdoor *	1	6.09	4
MMY-MAP0601T8	N/A	Three	Outdoor *	1	7.28	4
MMY-MAP0801T8	N/A	Three	Outdoor *	1	8.93	4
MMY-MAP1001t8	N/A	Three	Outdoor *	1	11.98	4
MMY-MAP1201T8	N/A	Three	Outdoor *	1	18.30	4
Heat Pump VRF (SMMS)						
MMY-MAP0501HT8	N/A	Three	Outdoor *	1	6.09	4
MMY-MAP0601HT8	N/A	Three	Outdoor *	1	7.28	4
MMY-MAP0801HT8	N/A	Three	Outdoor *	1	8.93	4
MMY-MAP1001HT8	N/A	Three	Outdoor *	1	11.98	4
MMY-MAP1201HT8	N/A	Three	Outdoor *	1	18.30	4
Heat Recovery VRF (SHRM)						
MCY-MAP0401HT	Max units 6	Single	Outdoor *	1	25.0	3
MCY-MAP0501HT	Max units 8	Single	Outdoor *	1	28.0	3
MCY-MAP0601HT	Max units 9	Single	Outdoor *	1	31.0	3

Note: * On SMMS / SHRM / Mini SMMS Equipment indoor units require a separate 230 volt supply, obtained via an internal ring main or similar.

Refrigeration Details

Model	Main Pipe (sub pipe)			Branch Pipe		Max Pipe Length m	Max sub Length m	Max Brch Length m	Prchg m	Add Chg g/m
	Discharge Inches	Liquid Inches	Suction Inches	Liquid Inches	Suction Inches					
Twin Splits										
RAV-SM1101/2AT-E	n/a	3/8	5/8	1/4	1/2	50	n/a	15	20	40
RAV-SM1401/2AT-E	n/a	3/8	5/8	3/8	5/8	50	n/a	15	20	40
Multi Splits										
RAV-SP1100/2AT-E	n/a	3/8	5/8	1/4	1/2	70	n/a	15	20	40
RAV-SP1400/2AT-E	n/a	3/8	5/8	3/8	5/8	70	n/a	15	20	40

*In all cases the branch pipes are the standard indoor unit pipe sizes, for more detailed information refer to the relevant technical manual.

Additional Refrigerant SMMS

Liquid pipe size	SMMS Charge rate (kg/m)
1/4"	0.025
3/8"	0.055
1/2"	0.105
5/8"	0.160
3/4"	0.250
7/8"	0.350

Trim charge SMMS (ONLY)										
HP	1	2	3	correction	HP	1	2	3	4	correction
5	5			0	28	10	10	8		-2.0
6	6			0	30	10	10	10		0
8	8			1.5	32	8	8	8	8	-6.0
10	10			2.5	32	12	10	10		1.0
12	12			3.5	34	10	8	8	8	-6.0
14	8	6		0	34	12	12	10		3.0
16	8	8		0	36	10	10	8	8	-6.0
18	10	8		0	36	12	12	12		4.0
20	10	10		3.0	38	10	10	10	8	-6.0
22	8	8	6	0	40	10	10	10	10	-5.0
22	12	10		5.0	42	12	10	10	10	-4.0
24	8	8	8	-4.0	44	12	12	10	10	-2.0
24	12	12		7.0	46	12	12	12	10	0
26	10	8	8	-4.0	48	12	12	12	12	2.0

Additional Refrigerant

Mini SMMS	
Liquid pipe size	Charge rate (kg/m)
1/4"	0.025
3/8"	0.055
Trim charge Mini SMMS	
0401	0501
-0.8	-0.4
0601	0

SHRM2		Trim charge SHRM (ONLY)				
Liquid pipe size	SHRM Charge rate (kg/m)	HP	1	2	3	correction
1/4"	0.0325	8	8			2.0
3/8"	0.0715	10	10			2.5
1/2"	0.1365	12	12			3.0
5/8"	0.208	16	8	8		-1.5
3/4"	0.325	18	10	8		0
7/8"	0.455	20	10	10		2.0
		24	8	8	8	-4.5
		26	10	8	8	-3.0
		28	10	10	8	-1.5
		30	10	10	10	0

SMMS system make up chart

Model reference MMY	Duty HP	Cooling Capacity kW	Heating capacity kW	Outdoor unit combination					Max. Indoor units
				0501	0601	0801	1001	1201	
MAP0501HT8	5	14	16	1					8
MAP0601HT8	6	16	18		1				10
MAP0801HT8	8	22.4	25			1			13
MAP1001HT8	10	28	31.5				1		16
MAP1201HT8	12	33.5	37.5					1	20
MAP1401HT8	14	38.4	43		1	1			23
MAP1601HT8	16	45	50			2			27
MAP1801HT8	18	50.4	56.5			1	1		30
MAP2001HT8	20	56	63				2		33
MAP2201HT8	22	61.5	69		1	2			37
							1	1	37
MAP2401HT8	24	68	76.5			3			40
								2	40
MAP2601HT8	26	73	81.5			2	1		43
MAP2801HT8	28	78.5	88			1	2		47
MAP3001HT8	30	84	95				3		48
MAP3201HT8	32	90	100			4			48
							2	1	48
MAP3401HT8	34	96	108			3	1		48
							1	2	48
MAP3601HT8	36	101	113			2	2		48
								3	48
MAP3801HT8	38	106.5	119.5			1	3		48
MAP4001HT8	40	112	126.5				4		48
MAP4201HT8	42	118	132				3	1	48
MAP4401HT8	44	123.5	138				2	2	48
MAP4601HT8	46	130	145				1	3	48
MAP4801HT8	48	135	150					4	48

SHRM2 system make up chart

Model reference MMY	Duty HP	Cooling Capacity kW	Heating capacity kW	Max. Indoor units			Max. Indoor units
				0802	1002	1202	
MAP0802HT8	8	22.4	25.0	1			8
MAP1002HT8	10	28.0	31.5		1		10
MAP1202HT8	12	33.5	35.5			1	13
MAP1602HT8	16	45.0	50.0	2			16
MAP1802HT8	18	50.4	56.5	1	1		20
MAP2002HT8	20	56.0	63.0		2		23
MAP2402HT8	24	68.0	76.5	3			27
MAP2602HT8	26	73.0	81.5	2	1		30
MAP2802HT8	28	78.5	88.0	1	2		33
MAP3002HT8	30	84.0	95.0		3		37

Note:
MMY-MAP1202FT8
is NOT modular

RAS Multi Split

Indoors to Outdoor Combinations

Indoor Unit Combinations				Outdoor Units			
A	B	C	D	RAS-M14EACV-E RAS-M14EAV-E	RAS-M18EACV-E RAS-M18EAV-E	RAS-3M23YACV-E RAS-3M26YAV-E	RAS-4M27YACV-E RAS-4M27YAV-E
10	-	-	-	P	P	P	P
13	-	-	-	P	P	P	P
16	-	-	-	0	P	P	P
10	10	-	-	P	P	P	P
13	10	-	-	P	P	P	P
16	10	-	-	0	P	P	P
13	13	-	-	0	P	P	P
16	13	-	-	0	P	P	P
16	16	-	-	0	P	P	P
10	10	10	-	0	0	P	P
13	10	10	-	0	0	P	P
16	10	10	-	0	0	P	P
13	13	10	-	0	0	P	P
16	13	10	-	0	0	P	P
13	13	13	-	0	0	P	P
16	16	10	-	0	0	P	P
16	13	13	-	0	0	P	P
16	16	13	-	0	0	P	P
16	16	16	-	0	0	0	P
10	10	10	10	0	0	0	P
13	10	10	10	0	0	0	P
16	10	10	10	0	0	0	P
13	13	10	10	0	0	0	P
16	13	10	10	0	0	0	P
13	13	13	13	0	0	0	P
16	16	10	10	0	0	0	P

Where: -
 10 = RAS-M10NKV, RAS-M10NKC, RAS-M10YDV & RAS10YDCV
 13 = RAS-M13NKV, RAS-M13NKC, RAS-M13YDV & RAS13YDCV
 16 = RAS-M16NKV, RAS-M16NKC, RAS-M16YDV & RAS16YDCV

Electrical Details

Model Outdoor		Phase	Power To	Start Amps	Run Amps	N° Cores to each indoor (+ Gnd)
Twin Splits						
RAS-14EACV-E	Cool Only	Single	Outdoor		5.63	Three
RAS-M18EACV-E	Cool Only	Single	Outdoor		7.32	Three
RAS-14EAV-E	Heat Pump	Single	Outdoor		5.83	Three
RAS-M18EAV-E	Heat Pump	Single	Outdoor		8.28	Three
Triple Split						
RAS-3M23YACV-E	Cool Only	Single	Outdoor		9.0	Three
RAS-3M26YAV-E	Heat Pump	Single	Outdoor		10.8	Three
Quad Splits						
RAS-4M27YACV-E	Cool Only	Single	Outdoor		10.6	Three
RAS-4M27YAV-E	Heat Pump	Single	Outdoor		10.6	Three
Note: Indoor units are powered from the outdoor via the interconnecting wiring						

Refrigeration Details

Model	Refrigerant Type	Branch	Pipe Sizes		Max Total Pipe Length	Max per indoor Length	Max Height	Pre-charge	Add Chg
			Liquid	Suction					
Twin Split			Inches	Inches	m	m	m	m	g/m
RAS-M14EACV-E	R410a	A	1/4	3/8	30	20	10	20	20
RAS-M18EACV-E	R410a	B	1/4	3/8	30	20	10	20	20
RAS-M14EAV-E	R410a	A	1/4	3/8	30	20	10	20	20
RAS-M18EAV-E	R410a	B	1/4	3/8	30	20	10	20	20
Triple Split									
RAS-3M23YACV-E	R410a	A	1/4	1/2	40	20	10	40	n/a
RAS-3M26YAV-E	R410a	B	1/4	3/8	50	25	15	50	n/a
		C	1/4	3/8					
Quad Split									
RAS-4M27YACV-E	R410a	A	1/4	1/2	70	25	15	70	n/a
RAS-4M27YAV-E	R410a	B	1/4	3/8	70	25	15	70	n/a
		C	1/4	3/8					
		D	1/4	3/8					

RAS – Auto Restart Function

The indoor unit is equipped with an automatic restart facility that allows the unit to restart, at the last set operating conditions, after a power failure. The operation will resume without warning three minutes after power is restored. This feature is not set up when these systems are shipped from the factory, therefore it will need to be activated by the installing company.

Generally the process is the same for all RAS products since approx 2001 and is as follows:

To initiate auto restart:

1. Turn the power on. Green On/Off light will flash.
2. Set the system to operate using the remote controller. Green On/Off light will be on constantly.
3. Press and hold down the temporary button for three seconds.
4. The indoor unit will bleep three times to acknowledge set up. In most cases the green light changes to orange.
5. The system will continue to operate during this set up.
6. After set up the system may be stopped using the remote controller.

To cancel auto restart:

1. The system is operating. Green On/Off light will be on constantly.
2. Stop the system operating using the remote controller. Green On/Off light will extinguish.
3. Press and hold down the temporary button for three seconds.
4. The indoor unit will bleep three times to acknowledge cancellation.
5. The system will have stopped operating.

This feature cannot be set if the timer is in operation.

The louver will not swing, if it was previously set, when the system auto restarts.

Acoustic Data – RAS, RAV & MMY - Indoor Units

Cooling Only

Model	High	Med	Low
RAS-10UKP-ES4	52	46	39
RAS-13UKP-ES4	54	48	44
RAS-18UKP-ES4	55	52	48
RAS-24UKP-ES4	58	54	50
RAS-18UFP-ES3	56		
RAS-24UFP-ES3	59		
RAS-M10NKC-E3	49		41
RAS-M13NKC-E3	52		41
RAS-M16NKC-E	55		46
RAS-M10YDCV-E	44		36
RAS-M13YDCV-E	45		37
RAS-M16YDCV-E	46		38

Heat Pumps

Model	High	Med	Low
RAS-10UKHP-ES3	40	37	34
RAS-13UKHP-ES3	54	48	44
RAS-18UKHP-ES3	55	52	48
RAS-24UKHP-ES3	58	54	50
RAS18UFHP-ES3	56		
RAS-24UFHP-ES3	59		
RAS-10NKV-E	52	47	42
RAS-13NKV-E	53	48	42
RAS-16NKV-E	57	54	44
RAS-M10NKV-E	52		42
RAS-M13NKV-E	53		42
RAS-M16NKV-E	55		46
RAS-M10YDV-E	44		37
RAS-M13YDV-E	45		37
RAS-M16YDV-E	45	41	37

Outdoor Units

Heat Pumps		Cool Only	
RAS-10UAH-ES3	62	RAS-10UA-ES3	62
RAS-13UAH-ES3	64	RAS-13UA-ES3	64
RAS-18UAH-ES3	66	RAS-18UA-ES3	66
RAS-24UAH-ES3	71	RAS-24UA-ES3	71
RAS-10NAV-E	47		
RAS-13NAV-E	50	MMY-MAP0501T8	68
RAS-16NAV-E	51	MMY-MAP0601T8	69
		MMY-MAP0801T8	70
RAS-M18EAV-E	59	MMY-MAP1001T8	71
RAS-3M23EAV-E	61	MMY-MAP1201T8	72
RAS-4M27EAV-E	61		
MMY-MAP0501HT8	68		
MMY-MAP0601HT8	69		
MMY-MAP0801HT8	70		
MMY-MAP1001HT8	71		
MMY-MAP1201HT8	72		
MMY-MAP0802FT8	70		
MMY-MAP1002FT8	71		
MMY-MAP1202FT8	72		

The above figures are sound power levels, dB(A)

* Sound Pressure Level dB(A) @ 1m

Daisekai and Digital Inverter

Model	Cooling			Heating		
	High	Med	Low	High	Med	Low
RAS-10JKVP-E	42	33	25	43	34	25
RAS-10JAVP-E	45			47		
RAS-13JKVP-E	43	34	26	44	35	26
RAS-13JAVP-E	48			50		
RAS-B10EKVP-E	55		38	56		38
RAS-10EAVP-E	59			60		
RAS-B13EKVP-E	56		39	57		39
RAS-13EAVP-E	61			63		
RAS-16EKVP-E	58		41	58		41
RAS-16EAVP-E	62			63		
RAV-SM560XT-E	58	54	51			
RAV-SM800XT-E	61	57	52			
RAV-SM561KRT-E	54	51	48			
RAV-SM801KRT-E	60	56	51			
RAV-SM561CT-E	51	48	45			
RAV-SM801CT-E	53	51	48			
RAV-SM1101CT-E	56	53	50			
RAV-SM1401CT-E	58	55	52			
RAV-SM560UT-E	47	44	42			
RAV-SM800UT-E	49	46	43			
RAV-SM1100UT-E	54	51	48			
RAV-SM1400UT-E	57	53	49			
RAV-SM561BT-E	55	52	48			
RAV-SM801BT-E	55	52	48			
RAV-SM1101BT-E	57	54	51			
RAV-SM1401BT-E	59	56	53			
RAV-SM561/2AT-E	63			65		
RAV-SM801/2AT-E	65			67		
RAV-SM1101/2AT-E	70			71		
RAV-SM1401/2AT-E	70			71		
RAV-SP560/2AT-E	63			64		
RAV-SP800/2AT-E	64			66		
RAV-SP1100/2AT-E	66			68		
RAV-SP1400/2AT-E	70			71		

AI Group and/or LAN (Zone) Network Layout

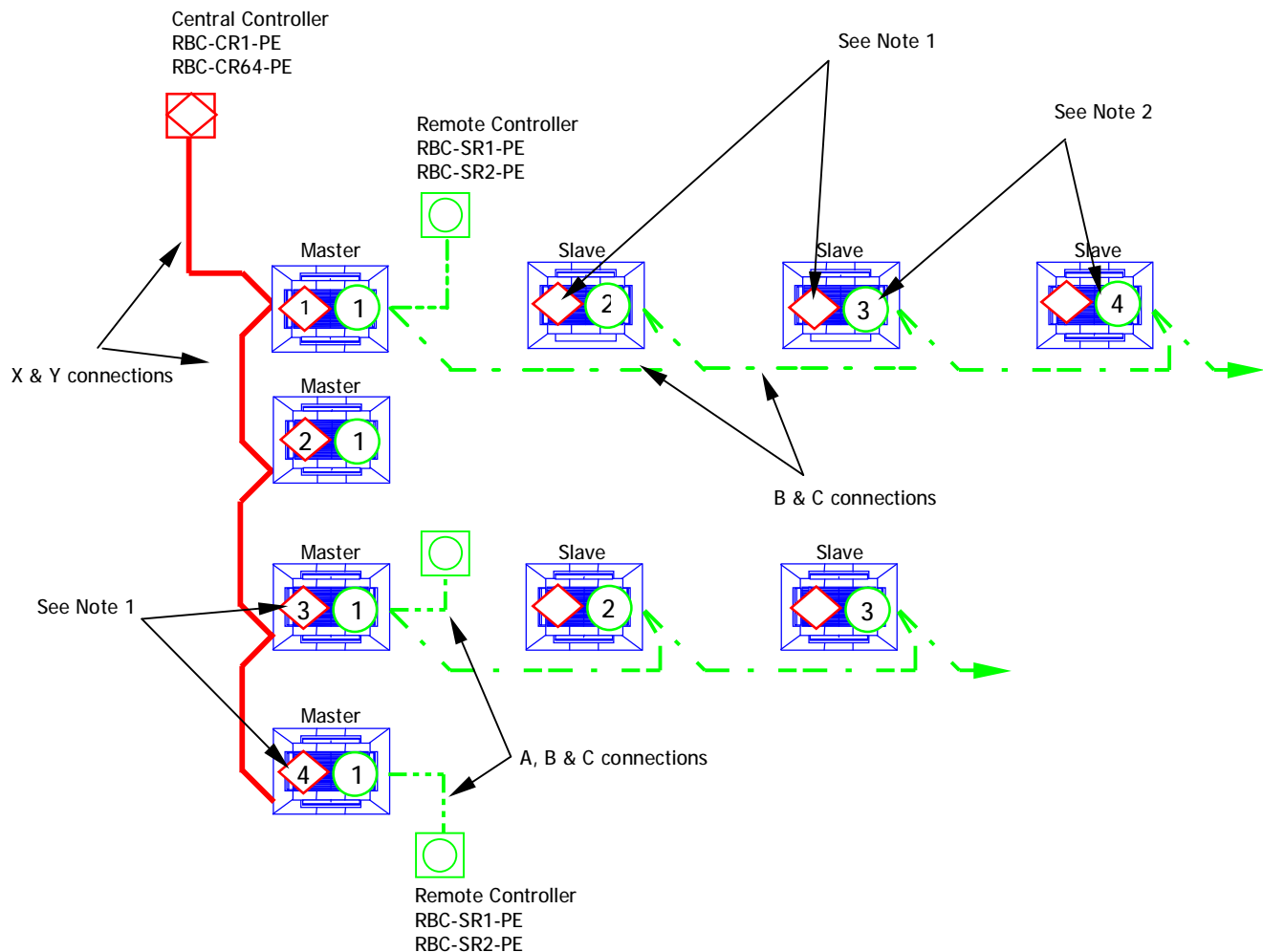

Notes;

1. Only set the Zone addresses, SW02, on the master indoor units. Leave the slave units set at the factory position.
2. The group address switch, rotary SW01, only needs to be adjusted on the slave units
3. All indoor units must be supplied from the same phase (usually via the outdoor unit)
4. When controlling a group via a central controller a remote controller **MUST** be installed.

◇ = LAN or Zone Address

○ = Group Address

--- = ABC Remote Controller wiring – 3 core flex > 0.75mm²

- . - = BC Group Wiring – 2 core flex > 0.75mm²

— = LAN or Zone wiring – 2 core twisted screened

0 - 500m = >1.5mm²

500 - 1000m = > 2.0mm²

AI Central Controller - Zone Address

RBC-CR1-PE and RBC-CR64-PE

If a standard remote controller has not been installed the Zone Addresses may be set using dip switches on the indoor printed circuit boards. This dipswitch is identified as "LAN ADDRESS" and "SW02", it is a seven-bit switch located centrally on the PCB.

Procedure

1. Turn off the power
2. Put 'Bit 7' of switch SW02 to the on position, this blocks a zone address set using a std remote controller.
3. Set zone address number by using ON/OFF combinations of 'Bits 1~6' of switch SW02.
4. Restore the power.

Switch SW02 (factory shipped position)

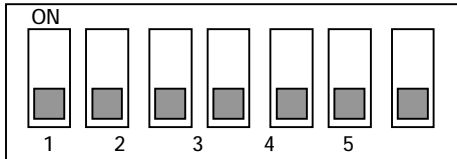

Example - set for Zone 24

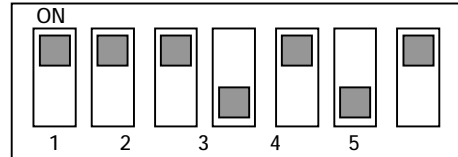

SW02 L.A.N. Address Switch							
Bit1	Bit 2	Bit3	Bit4	Bit5	Bit6	Bit7	
OFF	OFF	OFF	OFF	OFF	OFF	ON	Zone 1
ON	OFF	OFF	OFF	OFF	OFF	ON	Zone 2
OFF	ON	OFF	OFF	OFF	OFF	ON	Zone 3
ON	ON	OFF	OFF	OFF	OFF	ON	Zone 4
OFF	OFF	ON	OFF	OFF	OFF	ON	Zone 5
ON	OFF	ON	OFF	OFF	OFF	ON	Zone 6
OFF	ON	ON	OFF	OFF	OFF	ON	Zone 7
ON	ON	ON	OFF	OFF	OFF	ON	Zone 8
OFF	OFF	OFF	ON	OFF	OFF	ON	Zone 9
ON	OFF	OFF	ON	OFF	OFF	ON	Zone 10
OFF	ON	OFF	ON	OFF	OFF	ON	Zone 11
ON	ON	OFF	ON	OFF	OFF	ON	Zone 12
OFF	OFF	ON	ON	OFF	OFF	ON	Zone 13
ON	OFF	ON	ON	OFF	OFF	ON	Zone 14
OFF	ON	ON	ON	OFF	OFF	ON	Zone 15
ON	ON	ON	ON	OFF	OFF	ON	Zone 16

SW02 L.A.N. Address Switch							
Bit1	Bit 2	Bit3	Bit4	Bit5	Bit6	Bit7	
OFF	OFF	OFF	OFF	OFF	ON	ON	Zone 17
ON	OFF	OFF	OFF	OFF	ON	ON	Zone 18
OFF	ON	OFF	OFF	OFF	ON	ON	Zone 19
ON	ON	OFF	OFF	OFF	ON	ON	Zone 20
OFF	OFF	ON	OFF	OFF	ON	ON	Zone 21
ON	OFF	ON	OFF	OFF	ON	ON	Zone 22
OFF	ON	ON	OFF	OFF	ON	ON	Zone 23
ON	ON	ON	OFF	OFF	ON	ON	Zone 24
OFF	OFF	OFF	ON	ON	OFF	ON	Zone 25
ON	OFF	OFF	ON	ON	OFF	ON	Zone 26
OFF	ON	OFF	ON	ON	OFF	ON	Zone 27
ON	ON	OFF	ON	ON	OFF	ON	Zone 28
OFF	OFF	ON	ON	ON	OFF	ON	Zone 29
ON	OFF	ON	ON	ON	OFF	ON	Zone 30
OFF	ON	ON	ON	ON	OFF	ON	Zone 31
ON	ON	ON	ON	ON	OFF	ON	Zone 32

SW02 L.A.N. Address Switch							
Bit1	Bit 2	Bit3	Bit4	Bit5	Bit6	Bit7	
OFF	OFF	OFF	OFF	OFF	ON	ON	Zone 33
ON	OFF	OFF	OFF	OFF	ON	ON	Zone 34
OFF	ON	OFF	OFF	OFF	ON	ON	Zone 35
ON	ON	OFF	OFF	OFF	ON	ON	Zone 36
OFF	OFF	ON	OFF	OFF	ON	ON	Zone 37
ON	OFF	ON	OFF	OFF	ON	ON	Zone 38
OFF	ON	ON	OFF	OFF	ON	ON	Zone 39
ON	ON	ON	OFF	OFF	ON	ON	Zone 40
OFF	OFF	OFF	ON	OFF	ON	ON	Zone 41
ON	OFF	OFF	ON	OFF	ON	ON	Zone 42
OFF	ON	OFF	ON	OFF	ON	ON	Zone 43
ON	ON	OFF	ON	OFF	ON	ON	Zone 44
OFF	OFF	ON	ON	OFF	ON	ON	Zone 45
ON	OFF	ON	ON	OFF	ON	ON	Zone 46
OFF	ON	ON	ON	OFF	ON	ON	Zone 47
ON	ON	ON	ON	OFF	ON	ON	Zone 48

SW02 L.A.N. Address Switch							
Bit1	Bit 2	Bit3	Bit4	Bit5	Bit6	Bit7	
OFF	OFF	OFF	OFF	OFF	ON	ON	Zone 49
ON	OFF	OFF	OFF	OFF	ON	ON	Zone 50
OFF	ON	OFF	OFF	OFF	ON	ON	Zone 51
ON	ON	OFF	OFF	OFF	ON	ON	Zone 52
OFF	OFF	ON	OFF	OFF	ON	ON	Zone 53
ON	OFF	ON	OFF	OFF	ON	ON	Zone 54
OFF	ON	ON	OFF	OFF	ON	ON	Zone 55
ON	ON	ON	OFF	OFF	ON	ON	Zone 56
OFF	OFF	OFF	ON	ON	ON	ON	Zone 57
ON	OFF	OFF	ON	ON	ON	ON	Zone 58
OFF	ON	OFF	ON	ON	ON	ON	Zone 59
ON	ON	OFF	ON	ON	ON	ON	Zone 60
OFF	OFF	ON	ON	ON	ON	ON	Zone 61
ON	OFF	ON	ON	ON	ON	ON	Zone 62
OFF	ON	ON	ON	ON	ON	ON	Zone 63
ON	ON	ON	ON	ON	ON	ON	Zone 64

RAV Heat Pump Twin Splits

Details are given for both RAV 'classic' heat pumps and Digital Inverter Ranges, however there are some basic principles that must be adhered to. Both indoor units must be of the same style, duty and serve the same room. A common controller will be used, individual controls is not possible.

A generic arrangement is shown below:-

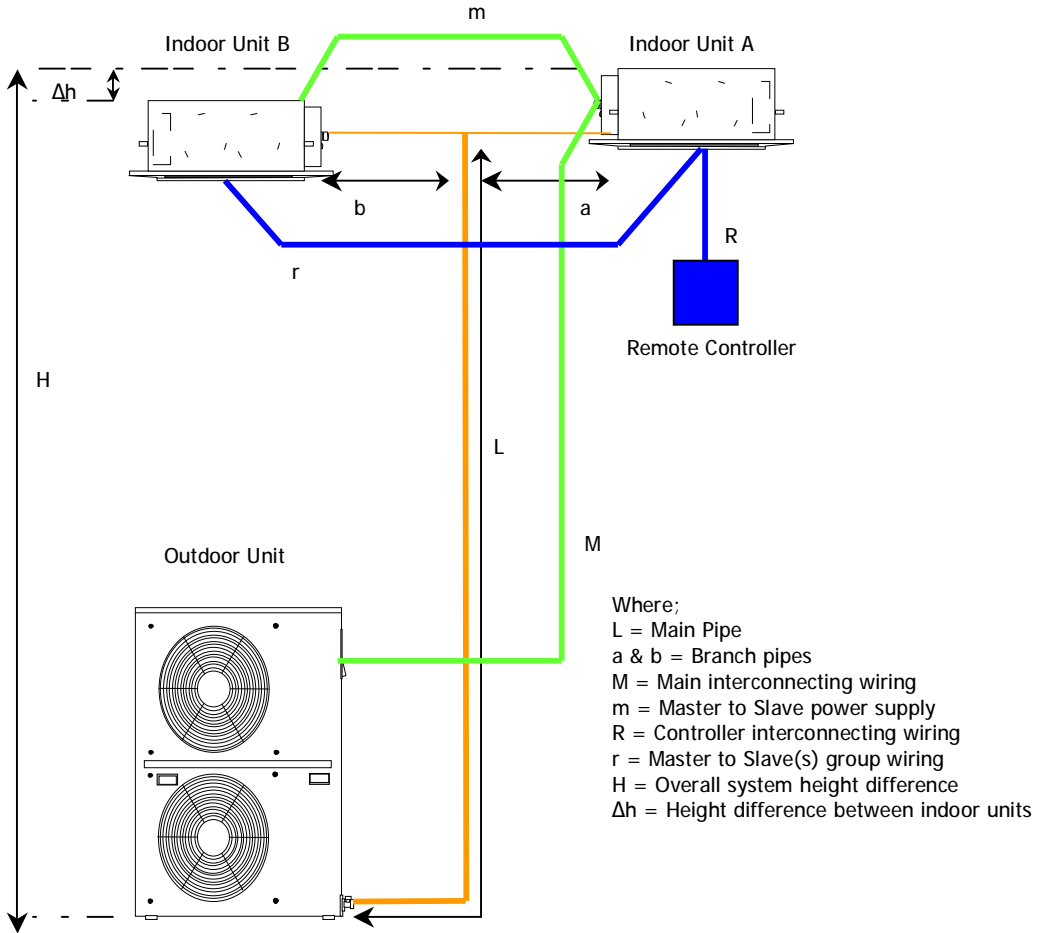

Configurations

When twinning a pair of digital inverter indoor units to one outdoor the twin kit detailed below must be used.

Digital Inverter		RAV 'classic'	
Outdoor Unit / Twin kit	Indoor Units x 2	Outdoor Unit (twin kit n/a)	Indoor Units x 2
		RAV-164AH-PE	RAV-104NH/TUH/SBH-PE RAV105KH-E
		RAV-264AH-PE RAV-264AH8-PE	RAV-134NH/KHH/TUH-PE RAV-135KH-E
RAV-SM1101/2 AT-E / RAV-SP1100/2AT-E (RBC-TWP30E)	RAV-SM56*KRT-E RAV-SM56*CT-E RAV-SM56*UT-E RAV-SM56*BT-E	RAV-364AH8-PE	RAV-164NH/SH/KH/CH/ UH/TUH/BH-PE RAV-165KH-E
RAV-SM1401/2 AT-E / RAV-SP1400/2AT-E (RBC-TWP50E)	RAV-SM80*KRT-E RAV-SM80*CT-E RAV-SM80*UT-E RAV-SM80*BT-E	RAV-464AH8-PE	RAV-264NH/SH/KH/CH/ UH/TUH/BH-PE RAV-265KH-E

RAV Heat Pump Twin Splits

The branch lengths, where feasible, should be equal, however a slight difference is permitted. Units will be of the same style, duty and serve the same room. A common controller will be used.

Pipe Specifications

Model (RAV-)	Piping Lengths (one way) & Sizes			Height Difference			Comments
	Main Pipe (L+a or L+b) Sizes	*Branch Pipe (a or b) Sizes	Branch Pipe differential length (a-b or b-a)	Outdoor Unit – Indoor Unit (H) Outdoor Unit higher	Indoor Unit higher	Indoor unit height difference (Δh)	
SM1100/1/2/AT-SM1400AT-E	Max 50m (actual) 5/8 & 3/8	Max 15m (actual) 1/2 & 1/4	Max 10m	Max 30m	Max 15m	Max 0.5m	Less than 10 bends
SP1100/1/2/AT-SP1400AT-E	Max 70m (actual) 5/8 & 3/8	Max 15m (actual) 5/8 & 3/8	Max 10m	Max 30m	Max 15m	Max 0.5m	Less than 10 bends
RAV-164AH-PE	Max 30m (actual) 1/2 & 1/4	Max 5m (actual) 1/2 & 1/4	Max 7m	Max 30m	Max 15m	Max 0.5m	Less than 10 bends
RAV-264AH-PE RAV-264AH8-PE	Max 30m (actual) 5/8 & 3/8	Max 5m (actual) 1/2 & 1/4	Max 7m	Max 30m	Max 15m	Max 0.5m	Less than 10 bends
RAV-364AH8-PE	Max 50m (actual) 3/4 & 3/8 (7/8 suction if over 30m)	Max 5m (actual) 1/2 & 1/4	Max 7m	Max 30m	Max 20m	Max 0.5m	Less than 10 bends
RAV-464AH8-PE	Max 50m (actual) 3/4 & 3/8 (7/8 suction if over 30m)	Max 5m (actual) 5/8 & 3/8	Max 7m	Max 30m	Max 20m	Max 0.5m	Less than 10 bends

* Branch piping length is for one leg so the max total branch is double this figure; please observe that the length difference "a-b" or "b-a" shall be below 7 or 10m as specified.

Electrical Details

Refer to schematic diagram on previous page

	Digital Inverter	RAV 'classic' heat pump
M = main interconnecting – power and coms	Terminals 1 2 3 3 core + earth (min 5 Amp rated)	Terminals 1 2 3 3 core + earth (min 5 Amp rated)
m = master to slave power only	Terminals 1 2 only 2 core + earth (min 5 Amp rated)	Terminals 1 2 only 2 core + earth (min 5 Amp rated)
R = master to remote – low voltage and coms	Terminals A & B	Terminals A B & C
r = master to group coms only	Terminals A & B	Terminals B & C only

Note:

The digital inverter systems will automatically set the internal addresses necessary.

The RAV classic range needs to have the address manually set at the indoor unit PCB. Using rotary switch SW01 set the master at 1 and the slave at 2. In addition SW05 switch, on both master and slave, needs to be set for twin operation, put 'bit1' to on and 'bit2' to off.

Additional Charge

Additional Amount (kg) = Main pipe [(L-18) x L] + Branch Pipe [(a+b-4) x I]

Model	Sizes (")	Main Pipes Pre-charge (m)	Add amount (kg/m) – [L]	Sizes (")	Branch pipes Pre-charge (m)	Add amount (g/m) – [I]
1100 / 1 / 2 AT	5/8 & 3/8	18	0.040	1/2 & 1/4	2	0.020
1400 / 1 / 2 AT	5/8 & 3/8	18	0.040	5/8 & 3/8	2	0.040
164AH	1/2 & 1/4	18	0.035	1/2 & 1/4	2	0.035
264AH98)	5/8 & 3/8	18	0.035	1/2 & 1/4	2	0.035
364AH8	3/4 & 3/8	18	0.035	1/2 & 1/4	2	0.035
464AH8	3/4 & 3/8	18	0.05	5/8 & 3/8	2	0.035

RBC-16DIF1-PE (16:1 Interface)

One 16:1 interface allows two multi controllers to be connected to one interconnecting terminal. Four multi controllers will require two 16:1 interfaces. This interface is purely a communication device; no refrigeration components are included in this kit. The indoor units are then connected, wired and piped, to the multi controllers in the normal VRF manner.

Electrical Connections

(Indoor units not shown)

Three Multi Controllers

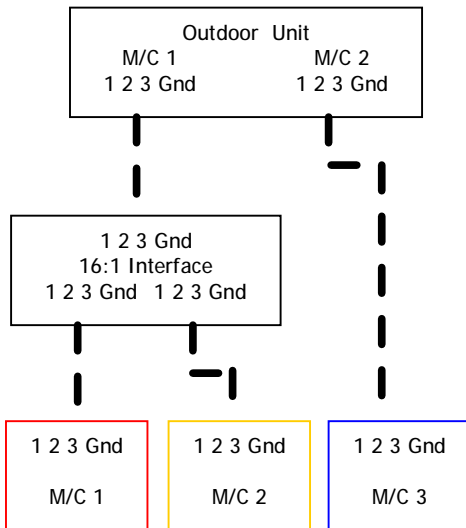

Four-Multi Controllers

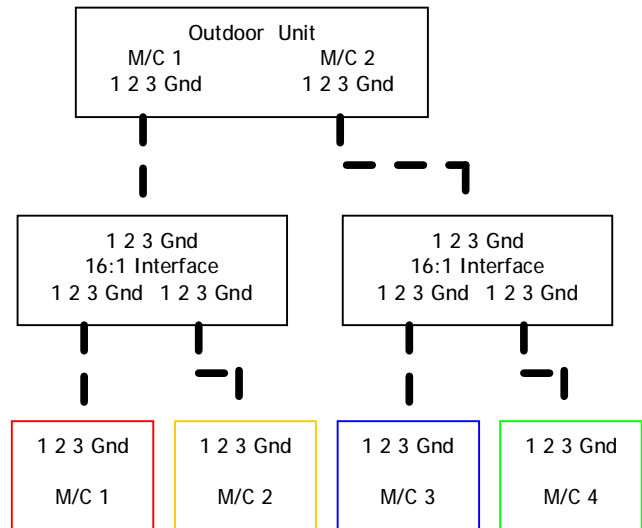

Piping Connections

When using three or four multi controllers the piping arrangements are different to the standard one / two multi controller installations.

Three Multi Controllers

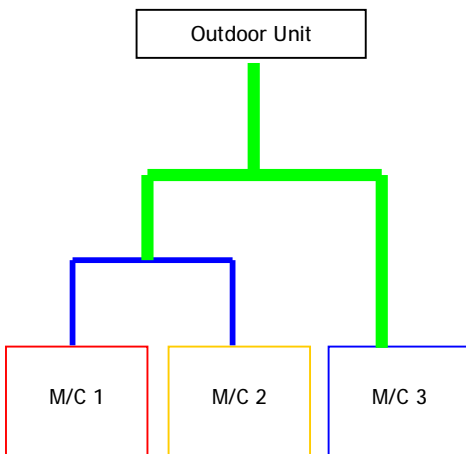

Four-Multi Controllers

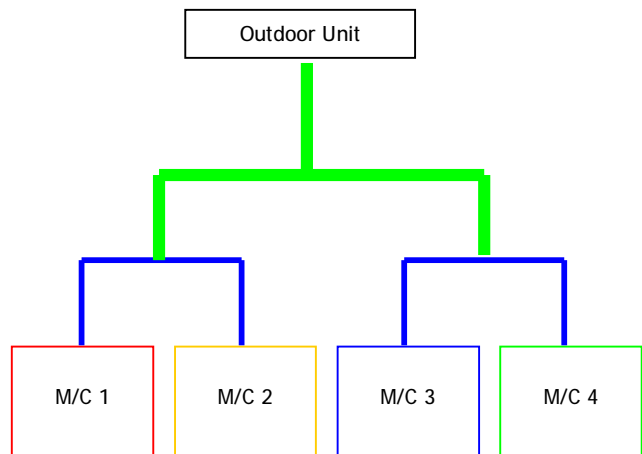

Where; — = Main Pipe Sizes
— = Sub Pipe Sizes

Pipe size specifications are detailed in the section headed "Twin and Multi-Split Refrigeration Details".

There should be a minimum 500mm of straight pipe before a T-piece, to ensure equal distribution.

Please note when using this accessory the formula for calculating the additional gas charge differs from the original, see next page.

RBC-16DIF1-PE cont.

Additional Gas Charge Calculation

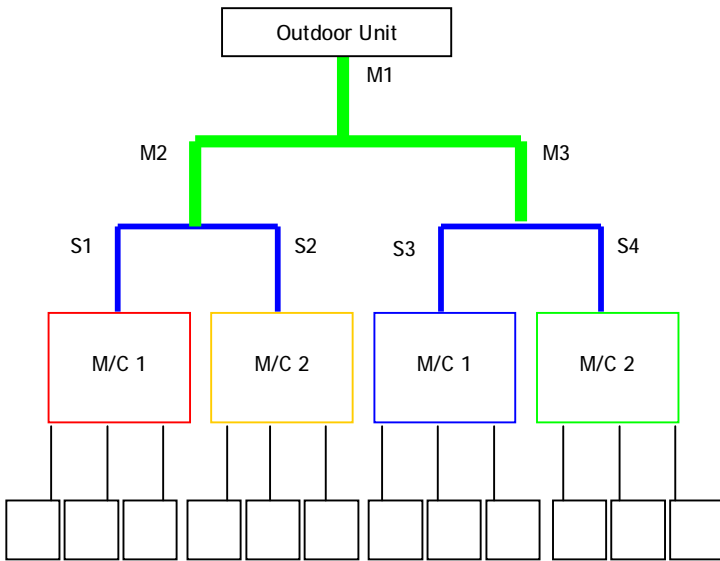

Outdoor Unit

Note 1

Additional charge for branch pipes
 RAV-10* ; 0.030 kg/m
 RAV-13* ; 0.030 kg/m
 RAV-16* ; 0.030 kg/m
 RAV-26* ; 0.045 kg/m
 RAV-36* ; 0.045 kg/m
 RAV-46* ; 0.045 kg/m

Main Pipes

Sub Pipes

Multi Controllers

Note 2

The kg/m quantity for the main pipe run for the MAR-F104 changes from 0.190 kg/m to 0.140 kg/m when using a 16:1 interface.

Branch Pipes

Indoor Units

MAR-C104	Main Pipes(M1+M2+M3) minus 2m	x 0.140 kg/m =	or
MAR-M104	Main Pipes(M1+M2+M3) minus 2m	x 0.190 kg/m =	or
MAR-F104	Main Pipes(M1+M2+M3) minus 2m	x 0.140 kg/m =	+
MAR-F105	1 st Longest Sub Pipe minus 1m	x 0.125 kg/m =	+
	2 nd Longest Sub Pipe minus 1m	x 0.125 kg/m =	+
	1 st Longest Branch Pipe minus 2m	x see note 1 =	+
	2 nd Longest Branch Pipe minus 2m	x see note 1 =	+
	3 rd Longest Branch Pipe minus 2m	x see note 1 =	+
	4 th Longest Branch Pipe minus 2m	x see note 1 =	+
	5 th Longest Branch Pipe minus 2m	x see note 1 =	+
	6 th Longest Branch Pipe minus 2m	x see note 1 =	+
	7 th Longest Branch Pipe minus 2m	x see note 1 =	+
	8 th Longest Branch Pipe minus 2m	x see note 1 =	_____

Additional Gas Charge = _____.

Factory charge		Max Total Charge
MAR-C104M8-PE	9.0 kg	26.6 kg
MAR-M104HTM8-PE	16.0 kg	36.3 kg
MAR-F104/5HTM8-PE	19.0 kg	36.3 kg

Permissible Piping Lengths and Differentials

Main Pipes; M2 or M3 – max 15m each; but must not exceed 10m difference in the two lengths.

Sub Pipes; S1 or S2 – max 15m each; but must not exceed 10m differences in the two lengths.

Sub Pipes; S3 or S4 – max 15m each; but must not exceed 10m differences in the two lengths.

Branch pipes, maximum individual length is 30m; the longest minus the shortest branch pipe must not exceed 10m on any one-multi controller.

Common Circuit Boards and Switch Settings

RAV "4" Series Heat Pump Indoor Unit

Type MCC1292
Part 43A69010

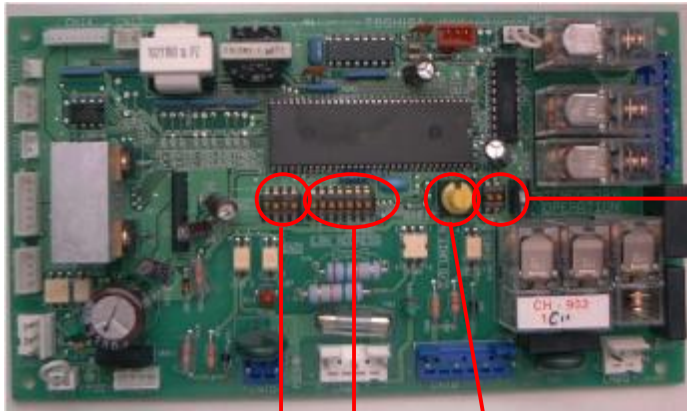

Air & Coil Sensor Offset Control

SW03 Sensor Offsets			
Bit	Bit	TA Heating Offset	
1	2		
ON	ON	0°C	
ON	OFF	+2°C	
OFF	ON	+4°C	
OFF	OFF	+6°C	
Bit	Bit	Trip	Reset
3	4		
ON	ON	54°C	52°C
ON	OFF	58°C	56°C
OFF	ON	60°C	58°C
OFF	OFF	Not Used	

Group Address Switch (Rotary)

SW01 Rotary	
Position 1	Group Master
Position 2	Slave 1
Position 3	Slave 2
Position 4	Slave 3
Position 5	Slave 4
	etc max 16 units

Twin & Auto Function Enable/Disable

SW05	
Bit1	
OFF	Single Split Operation
ON	Twin Split Operation
Bit2	
OFF	Auto Mode Enabled
ON	Auto Mode Disabled

Zone Address Switch (Local Area Network, LAN)

SW02 L.A.N. Address Switch							
Bit1	Bit 2	Bit3	Bit4	Bit5	Bit6	Bit7	
OFF	OFF	OFF	OFF	Only used with CR64 controller Normal setting both to OFF		Off if using rem com to zone address On when using SW02 to zone address	Zone 1
ON	OFF	OFF	OFF				Zone 2
OFF	ON	OFF	OFF				Zone 3
ON	ON	OFF	OFF				Zone 4
OFF	OFF	ON	OFF				Zone 5
ON	OFF	ON	OFF				Zone 6
OFF	ON	ON	OFF				Zone 7
ON	ON	ON	OFF				Zone 8
OFF	OFF	OFF	ON				Zone 9
ON	OFF	OFF	ON				Zone 10
OFF	ON	OFF	ON				Zone 11
ON	ON	OFF	ON				Zone 12
OFF	OFF	ON	ON				Zone 13
ON	OFF	ON	ON				Zone 14
OFF	ON	ON	ON				Zone 15
ON	ON	ON	ON				Zone 16

Note;
Details in bold are the Factory settings

Common Circuit Boards and Switch Settings

RAV "2 & 3" Series Heat Pump Indoor Unit

Type MCC1277
Part 43A69002

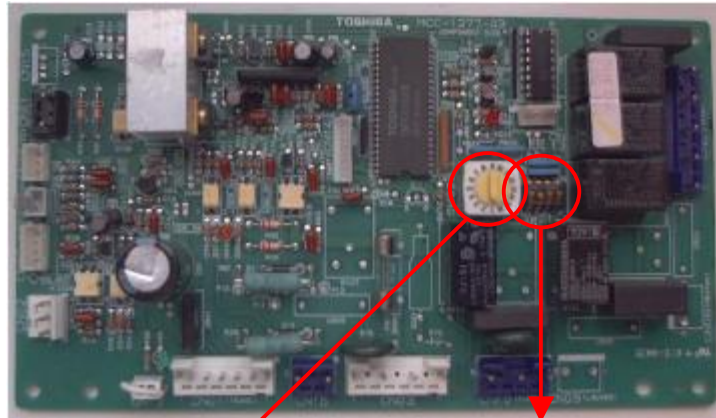

Group Address Switch (Rotary)

SW01 Rotary	
Position 1	Group Master
Position 2	Slave 1
Position 3	Slave 2
Position 4	Slave 3
Position 5	Slave 4
	etc max 16 units

Air & Coil Sensor Offset Control

SW03 Sensor Offsets			
Bit	Bit	TA Heating Offset	
1	2		
ON	ON	0°C	
ON	OFF	+2°C	
OFF	ON	+4°C	
OFF	OFF	+6°C	
Bit	Bit		
3	4	Trip	Reset
ON	ON	54°C	52°C
ON	OFF	58°C	56°C
OFF	ON	60°C	58°C
OFF	OFF	Not Used	

RAV "2,3 & 4" Series Cooling Only Indoor Unit

Type MCC1277
Part 43A69005

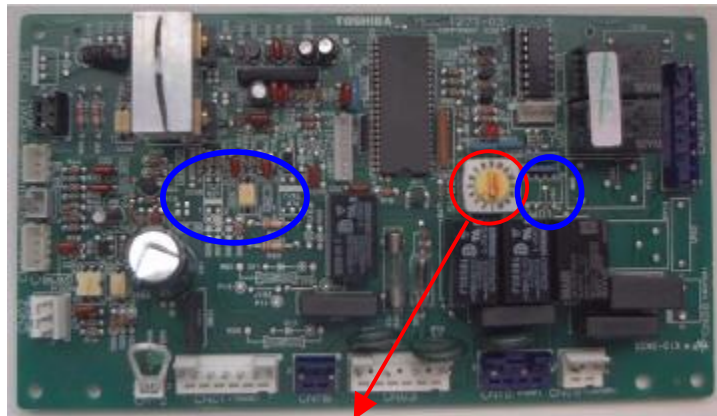

Group Address Switch (Rotary)

SW01 Rotary	
Position 1	Group Master
Position 2	Slave 1
Position 3	Slave 2
Position 4	Slave 3
Position 5	Slave 4
	etc max 16 units

Note; Both the above circuit boards have the same type number and visually are very similar. They are not interchangeable; the obvious differences are marked in blue on the lower picture.

Common Circuit Boards and Switch Settings

RAV "2,3 & 4" Series Heat Pump Outdoor Unit

Type MCC1275
Part 43A69006 ; 2 & 3 series
43A69011 : 4 series



Emergency Operation from Outdoor unit

It is possible to operate the a/c system from the outdoor unit by using the dipswitches detailed above.

1. Set Switch SW01 to required position.

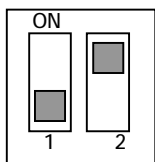

Cooling Mode

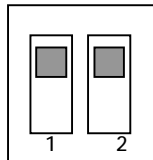

Heating Mode





2. Apply a short across pins CN28 and CN29 until the middle yellow, D08, illuminates, then remove the short. The LED will then extinguish and the indoor units will start, after a couple of minutes the outdoor unit will then start, LEDs D07 (yellow) and D10 (red) will light.
3. To stop the emergency operation, re-apply the short between CCN28 and CN29. LEDs D08 and D10 will extinguish and the a/c system will stop operating.
4. Reset SW01 to factory settings for normal operation.

Common Circuit Boards and Switch Settings

RAV "2,3 & 4" Series Heat Pump Outdoor Unit

Type MCC1275
 Part 43A69006 ; 2 & 3 series
 43A69011 : 4 series

Information given by LEDs

DIP Position	LED				Information
	D10	D09	D08	D07	
	TM	TM	TM	TM	Normal Operation
	ä	TM	TM	TM	Timer Short
	~	~	~	ä	21, High Pressure Trip
	~	~	~	~	18,19, Sensor Failure
	TM	TM	TM	TM	Normal Operation
	TM	TM	TM	~	N° Failures – First
	TM	TM	~	TM	N° failures – Second
	TM	TM	~	~	N° Failures – Third
	~	~	á	á	N° Failures – Fourth
	ä	~	á	á	18,19 Sensor Failure
	~	~	á	á	21, High Pressure Trip
<p>* Compressor Demand</p>  <p>Compressor Actual</p> 	TM	TM	TM	TM	Compressor Stop
	TM	TM	~	~	Speed 3
	TM	~	TM	TM	Speed 4
	TM	~	TM	~	Speed 5
	TM	~	~	TM	Speed 6
	TM	~	~	~	Speed 7
	~	TM	TM	TM	Speed 8
	~	TM	TM	~	Speed 9
	~	TM	~	TM	Speed 10
	~	TM	~	~	Speed 11
	~	~	TM	TM	Speed 12
	~	~	TM	~	Speed 13
	~	~	~	TM	Speed 14
	~	~	~	~	Speed 15

* Note; The compressor speed is fixed on the RAV series.

TM = Off

~ = Lit

á = Flashing at 1hz

ä = Flashing at 5hz

TOSHIBA Circuit Boards

By Type Number	MODEL No.	PART No.	COMMENTS					
	ET 420	RAV-1800UDHE8	431 50 101		MCC 1070	RAV-160, 260, 360, 460BH	431 69 544	
	H92C-11(CorGZ)	RAV-G1253HE8-E	431 51 210	Type No differ - Part No the same	MCC 1070	RAV-453, 713KHE(8)	431 69 463	
	H92C-11(CorGZ)	RAV-G1003HE8	431 51 210	Type No differ - Part No the same	MCC 1070	RAV-453, 713, 1003, 1253UHE(8)	431 69 463	
	H92C-11(CorGZ)	RAV-640AH8A	431 51 210	Type No differ - Part No the same	MCC 1070	RAV-1003, 1253FHE8	431 69 463	
	MCC 26	RAS-30PKHE	430 69 878		MCC 1070	RAV-453, 713LHE(8)	431 69 463	
	MCC 35	RAV-450, 710, 1000, 1250UHJE/UHE8	431 69 281		MCC 1070	RAV-160, 200, 260KH	431 69 544	
	MCC 35	RAV-451, 561, 711KHJE/KHE8	431 69 327		MCC 1074	RAV-S453, 713, 1003, 1253HE/HE8	431 69 469	Control PCB
	MCC 35	RAV-450, 710LHJE/LHE8	431 69 311		MCC 1074	RAV-160, 200, 260, 360, 460AH(8)	431 69 469	Control PCB
	MCC 35	RAV-450, 560, 710, 1000, 1250CHJE/CHE8	431 69 282		MCC 1075	RAV-360, 460AH8	431 69 467	Relay PCB
	MCC 35	RAV-1000, 1250FH(Y/M)E8	431 69 307		MCC 1075	RAV-S1003, 1253HE8	431 69 467	Relay PCB
	MCC 175	RAS-30BK	430 69 570		MCC 1076	RBC-TK45E	431 69 502	Japanese
	MCC 175	RAS-30GK	430 69 264		MCC 1080	RAS-45BKHV	430 69 617	
	MCC 191	RAV-1006, 1256UE8	431 69 429	Twin Fan Connections	MCC 1200	RAV-160, 260, 360, 460UH-P	431 69 578	
	MCC 191	RAV-457, 458, 716, 717UE(8)	431 69 430	Single Fan Connections	MCC 1200	RAV-161, 261, 361, 461CH-P	431 69 578	
	MCC 194	RAS-22EAHV	430 69 174	Power PCB	MCC 1200	RAV-160, 161, 260, 360, 460BH-P	431 69 578	
	MCC 195	RAS-22EAHV	430 69 173	Control PCB	MCC 1200	RAV-640DH8A	431 69 562	
	MCC 197	RAS-28EAHV	430 69 191	Power PCB	MCC 1200	RAV-160, 260KH-P	431 69 578	
	MCC 198	RAS-28EAHV	430 69 190	Control PCB	MCC 1201	RAV-160, 260, 360, 460AH(8)-P	431 69 577	Control PCB
	MCC 204	RAS-22EKHV	430 69 183		MCC 1201	RAV-640AH8A	431 69 561	
	MCC 204	RAS-28EKHV	430 69 187		MCC 1204	MAR-M51HTME	431 69 536	Inverter Board
	MCC 223	RAV-560, 710, 1250UDHE8	431 69 337		MCC 1210	RBM-Y1042E-E	431 6V 026	Multi Contr - 8/10HP Two Pipe
	MCC 255	RAS-22GKH	430 69 388		MCC 1210	RBM-Y1032E-E	431 6V 026	Multi Contr - 8/10HP Two Pipe
	MCC 255	RAS-30SKH	430 69 388		MCC 1210	RBM-Y1031E	431 69 528	Multi Contr - 5HP
	MCC 347B	RAS-20BK	430 69 605		MCC 1211	MAR-M51HTME	431 69 547	Interface Board - 5HP
	MCC 364	HAS-20LAHV	430 69 635	Control PCB	MCC 1211	MAR-M81HTM8-E	431 6V 027	Interface Board
	MCC 364	RAS-45BAHV	430 69 635	Control PCB	MCC 1211	MAR-M101HTM8-E	431 6V 027	Interface Board
	MCC 369	HAS-20LAHV	430 69 642	Power PCB	MCC 1222	RBM-Y1031FE(-E)	431 69 627	Multi Contr - 8/10HP Three Pipe
	MCC 369	RAS-45BAHV	430 69 642	Power PCB	MCC 1222	RBM-Y1041FE(-E)	431 69 627	Multi Contr - 8/10HP Three Pipe
	MCC 416	RAC-06, 08LW	430 68 004		MCC 1223	MAR-F101HTM8(-E)	431 69 628	Interface Board
	MCC 446	RAS-13PAHT	430 68 190		MCC 1223	MAR-F81HTM8(-E)	431 69 628	Interface Board
	MCC 446	HAS-13LAHT	430 69 729		MCC-1223	MAR-F105HTM8-PE	43A 69 036	Interface Board
	MCC 446	RAS-10YAHT	430 69 096		MCC 1231	RAV-360, 460AH8-P	431 69 579	Relay PCB
	MCC 450	RAS-10YKHT	430 68 109		MCC 1237	RAV-161, 261, 361, 461AH(8)-P	43A 69 001	
	MCC 476	HAS-20LUHV	430 68 010		MCC 1238	RAV-180, 240K-P	431 69 583	
	MCC 476	HAS-13LUHT	430 68 009		MCC 1238	RAV-180, 240, 360,460U-P	431 69 583	
	MCC 490	RAS-13PKHT	430 69 751		MCC 1238	RAV-181, 241, 361, 461C-P	431 69 583	
	MCC 531	RAS-09PKH, UKH, UKR	430 69 189		MCC-1342	MAR-F105HTM8-PE	43A 69 036	IPDU Board
	MCC 562A	RAS-13UKR	430 68 263		MCC 1251	MAR-F101HTM8(-E)	431 69 623	Inverter Board
	MCC 562A&B	RAS-13UKH	430 68 265		MCC 1251	MAR-M81HTM8(-E)	431 6V 025	Inverter Board ThE
	MCC 593	RAS-18UKHT	430 68 331		MCC 1251	MAR-F81HTM8(-E)	431 69 623	Inverter Board
	MCC 597	RAS-18UAHT	430 68 339		MCC 1251	MAR-M101HTM8-E	431 6V 025	Inverter Board ThE
	MCC 603A&B	RAS-13EKH/UKH-G	430 68 354		MCC 1252	MAR-M81HTM8-E	431 69 624	Gate Drive
	MCC 639	RAS-13NK	430 68 358		MCC 1252	MAR-M101HTM8-E	431 69 624	Gate Drive
	MCC 639	RAS-13EK	430 69 406		MCC 1252	MAR-F81HTM8(-E)	431 69 624	Gate Drive
	MCC 660	RAS-09EK/EKH	430 68 418		MCC 1252	MAR-F101HTM8(-E)	431 69 624	Gate Drive
	MCC 702	RAC-08EW-E	430 68 439		MCC-1387	MAR-F105HTM8-PE	43A 69 037	Communication Board
	MCC 713	RAS-10SK-E/SKH-E	43T 69 008		MCC 1275	RAV-162, 202, 262, 362, 462AH(8)-PE	43A 69 003	
	MCC 713	RAS-13SK-E/SKH-E	43T 69 006		MCC 1275	RAV-363, 463AH8-PE	43A 69 006	
	MCC 1070	RAV-453, 713, 1003, 1253CHE(8)	431 69 463		MCC 1275	RAV-1*4AH(8)-PE	43A69011	
					MCC 1277	RAV-132, 162, 262, 362, 462UH-PE	43A 69 002	
					MCC 1277	RAV-133, 163, 203, 263KH-PE	43A 69 002	
					MCC 1277	RAV-182, 242, 362, 462B-PE	43A 69 005	

MCC 1277	RAV-182, 242, 362, 462U-PE	43A 69 005			MCC 900	RAS-10/13 JKVP-E	4306S405	LED PCB
MCC 1277	RAV-183, 243K-PE	43A 69 005				RAS-B10EKVP-E	4306S609	PCB ASS.
MCC 1277	RAV-133, 163TU-PE	43A 69 005				RAS-B13EKVP-E	4306S610	PCB ASS.
MCC 1277	RAV-182, 242K(W)-PE	43A 69 005				RAS-B16EKVP-E	4306S611	PCB ASS.
MCC 1277	RAV-132, 162, 262, 362, 462CH-PE	43A 69 002			MCC 5009	RAS-10/13/16EAVP-E	4306S612	
MCC 1277	RAV-103, 133, 163, 263NH-PE	43A 69 002			MCC 509	RAS-M14EAV/EACV-E	4306S666	IPDU
MCC 1277	RAV-132, 182, 242, 362, 462C-PE	43A 69 005			MCC 509	RAS-M18EAV/EACV-E	4306S667	IPDU
MCC 1277	RAV-163, 263SH-PE	43A 69 002			MCC 5015	RAS-M14/18/EAV/EACV-E	4306S646	Communication PCB
MCC 1277	RAV-103, 133, 163TUH-PE	43A 69 002				RAS-M10EKCV-E	4306S609	
MCC 1277	RAV-162, 262, 362, 462BH-PE	43A 69 002				RAS-M13EKCV-E	4306S610	
MCC 1277	RAV-W182, 362U-PE	43A 69 005				RAS-M16EKCV-E	4306S611	
MCC 1277	RAV-162, 202, 262KH-PE	43A 69 002				RAS-M10NKCV-E	43T69474	
MCC 1277	RAV-362, 462FH-E	431 6V 002				RAS-M13NKCV-E	43T69475	
MCC 1277	RAV-162, 262LH-E	431 6V 002				RAS-M16NKCV-E	43T69335	
MCC 1292	RAV-1*4BH-PE	43A69010				RAS-M10NKV-E	43T69476	
MCC 1292	RAV-1*4CH/CHR-PE	43A69010				RAS-M13NKV-E	43T69477	
MCC 1292	RAV-1*4KH/KHR-PE	43A69010				RAS-M16NKV-E	43T69332	
MCC 1292	RAV-1*4SH/SHR-PE	43A69010				RAS-10NKV-E	43T69472	
MCC 1292	RAV-1*4TUH-PE	43A69010				RAS-13NKV-E	43T69473	
MCC 1292	RAV-1*4UH-PE	43A69010				RAS-16NKV-E	43T69399	
SB 30	RBC-TK45ES-HP	tba	U.K.		MCC-1429	MAP1201/1001/0801/0601/0501/HT7	4316V246	Interface
SB 31	RBC-TK45ES-HP/CO	tba	U.K. Noise Filter			MAP1201/1001/0801/0601/0501/0802/1002/1202/HT7/FT8	4316V237	Fan IPDU
SB 35	RBC-TK45ES-CO	tba	U.K.		MCC 1502	MAP1201/1001/0801/0601/0501/0802/1002/1202/HT7/FT8	4316V245	IPDU
MCC 813	RAV-SM 560AT-E	4316V182			MCC 1429	MAP0801/1001/1201FT8	4316V249	Interface
MCC 1359	RAV-SM 800AT-E	4316V184	IPDU		MCC 1429	MAP0802/1002/1202	4316V265	Interface
MCC 1398	RAV-SM 800AT-E	4316V183	CDB					
MCC 1438	RAV-SM1100AT-E	4316V218	IPDU					
MCC 1398	RAV-SM1100AT-E	4316V217	CDB		MCC 758	RAS-M18YAV-E	4306S181	
MCC 1438	RAV-SM400AT-E	4316V219	IPDU		MCC 775	RAS-M18YAV-E	4306S178	
MCC 1398	RAV-SM1400AT-E	4316V217	CDB		MCC 758	RAS-M18YACV-E	4306S180	
MCC 1359	RAV-SP 560/800 AT-E	4316V184	IPDU		MCC 775	RAS-M18YACV-E	4306S177	
MCC 1398	RAV-SP 560/800 AT-E	4316V231	CDB		MCC 758	RAS-3M23 YACV-E	4306S191	
MCC 1438	RAV-SP 1100/1400 AT-E	4316V219	IPDU		MCC 775	RAS-3M23 YACV-E	4306S190	
MCC 1398	RAV-SP 1100/1400 AT-E	4316V231	CDB		MCC 818	RAS-3M26 YAV-E	4306S268	CDB
	RAV-SM561/801KRT-E	43T69424			MCC 1359	RAS-3M26 YAV-E	4306V009	IPDU
MCC 1402	RAV-SM561/801/1101/1401 BT	4316V226			MCC 818	RAS-4M27 YAV-E	4306S267	CDB
MCC 1402	RAV-SM561/801/1101/1401 CT	4316V230			MCC 1359	RAS-4M27 YAV-E	4306V009	IPDU
MCC 1403	RAV-SM 560 / 800 BT	4316V189			MCC 818	RAS-4M27 YACV-E	4306S269	CDB
	RAV-SM560 XT	43T69348			MCC 1359	RAS-4M27 YACV-E	4306V009	IPDU
	RAV-SM800 XT	43T69349			MCC 875	RAS-13 YDV/YDCV-E	4306S336	
MCC 1370B	RAV-SM560 KRT	43T69346	PCB ASS.		MCC 875	RAS-16 YDV/YDCV-E	4306S337	
MCC 1370A	RAV-SM800 KRT	43T69347	PCB ASS.		MCC 772	RAS-10 YKV-E	43T69049	
MCC 1337	RAV-SM560/800 KRT	43T69325	AI PCB		MCC 772	RAS-13 YKV-E	43T69050	
MCC 819-02	RAV-SM560/800 KRT	43T69066	LED PCB		MCC 772	RAS-16 YKV-E	43T69069	
MCC 1402	RAV-SM560/800 UT	4316V188			MCC 772	RAS-10 YKCV-E	43T69046	
MCC 1402	RAV-SM/SP1100/1400 UT	4316V220			MCC 772	RAS-13 YKCV-E	43T69047	
MCC-5009	RAV-SM561/801AT-E	4316V268			MCC 772	RAS-16 YKCV-E	43T69048	
MCC-1531	RAV-SM1101/1401AT-E	4316V255	CDB		MCC 766	RAS-10/13/16 YKV/YKCV-E	43T69031	LED PCB
MCC-1438	RAV-SM1101/1401AT-E	4316V264	IPDU					
MCC 813	RAS-10/13 JAVP-E	4306S380						
MCC 891	RAS-10 JKVP-E	4306S382	PCB ASS.					
MCC 891	RAS-13 JKVP-E	4306S383	PCB ASS.					

Toshiba Outdoor Unit Fan Motors

Winding Resistance at 20°C

Model No.	Type No.	Part No.	Upper/ Lower	Speeds	Black- Red	Black- White	Black- Orange	Black- Blue
HAS-13LAHT RAS-10YAHT RAS-13PAHT	AF 230 25N/P	43021852		2	363	335		
HAS-20LAHV RAS-45BAHV	AF 230 50L	43021829		2	116	128		
MAR-M/F81HTM8-E MAR-M/F101HTM8-E MAR-M/F102HTM8-PE MAR-F105HTM8-PE	STF 200 150C STF-200-350A	43121545 43A21022	BOTH	2	48.5	34		32.4
RAS-07/09EA/EAH RAS-09UAH/PAH	UE6 21 A5P	43021928		1	366.2	368.5		
RAS-09UA	UE6 21 A5P	43021924		1	366.2	368.5		
RAS-10SA/SAH-E	UE21 SJ5P	43T21001		1	370	370		
RAS-13EAH/SAH	AF 230 28P	43021984		1	198	160		
RAS-13EA/SA-E	UE6 331 C5P	43021981		1	205	426.7		
RAS-13UA RAS-13UAH(-G)	AF 23 26E	43021958		1	266.8	374.5		
RAS-18UAHT	AF 230 50N	43021978		3	140	117.8	59.3	
RAS-20BA	AF 230 18K	43021827		1	367.5	380		
RAS-22EAHV RAS-28EAHV	AF 230 20L	43021679		1	352.2	360.8		
RAS-22GAH	AF 240 20P	43021727		1	365	378		
RAS-30BA/GA	AF 210 26B	43021615		1	3379.4	554.1		
RAS-30SAH	AF 230 24C	43021788		1	295	287		
RAV-132A-PE RAV-182A-PE RAV-363A8-PE RAV-463A8-PE	SMF 230 39N3	43A21012	Lower	3	97.1	101.9	295	509
RAV-161/2AH-PE RAV-361/2/3AH8-PE RAV-461/2/3AH8-PE	SMF 230 39N1 SMF 230 39N2	43A21003	Lower	2 1	98.6	97.8		288.8
RAV-242A(8)-PE RAV-363A8-PE RAV-463A8-PE	SMF 230 63N3	43A21011	Upper	3	92	106.5	260	365
RAV-261/2AH(8)-PE RAV-361/2/3AH8-PE RAV-461/2/3AH8-PE	SMF 230 63N1 SMF 230 63N2	43A21002	Upper	2 1	75	107.2		256.4
RAV-460/2A8-PE	AF 220 105SE	43121506	Both	2				
RAV-G1003HE8(-E)	AF 200 105D	43121466		2	42.2	28.9		14.5
RAV-G1253HE8(-E)	STF 200 150B	43121468		2	50.1	33.2		59
RAV-S1003HE8 RAV-S1253HE8 RAV360A8-P	AF 230 63N	43121464	Upper	2	40.3	43.7		27.5

Model No.	Type No.	Part No.	Upper/ Lower	Speeds	Black- Red	Black- White	Black- Orange	Black- Blue
RAV-S1003HE8 RAV-S1253HE8	AF230 39N	43121463	Lower	1	44.7	45.2		
RAV-360A8-P								
RAV-S1800CHE8 RAV-S2000HE8 RAV-640DH8A	AF 230 110D	43121295		1	23.8	65		
RAV-S2500HE8	AF 200 150A	43121266		1	15.5	23		
RAV-S450HJE RAV-S560HJE RAV-S1000HE8 RAV-S1250HE8	AF 230 39K	43121273	Lower	1	53.3	54.2		
RAV-S453HE RAV-200AH RAV-180A-P	AF 230 39P	43121473		2				
RAV-S455E RAV-S458E	AF 230 28K	43121360		1	22	33.3		
RAV-S457E RAV-S717E	AF 230 60V	43121431		1				
RAV-S710HE8 RAV-S1000HE8 RAV-S1250HE8 RAV-S1005E8	AF 230 63K	43121287	Upper	1	40	43.2		
RAV-S713HE8 RAV-240A/A8-P	AF 230 63P	43121489		2				
RAV-S715(8) RAV-S1255E8	AF 220 105B	43121326	Both	1	21.9	50.8		
RAV-SM560 AT-E RAV-SM 800 AT-E RAV-SM 1100 AT-E RAV-SM 1400 AT-E	1CF-140-43-1 1CF-140-63-1 1CF-140-43-2 1CF-140-63-2	4302C033 43121693 4302C040 43121704	Both Both					
RAV-SP 560/800 AT-E RAV-SP1100/1400 AT-E	1CF-140-63-2 1CF-140-63-2	43121704 43121704	Both					
RAS 10/13 JAVP-E RAS-M18 YAV/YACV-E RAS-3M23 YACV-E RAS-3M26 YAV-E RAS-4M27 YACV-E RAS-4M27 YAV-E	1CF-140-43-1 1CF-140-40-7 1CF-140-40-4 1CF-140-60-1 1CF-140-60-1 1CF-140-60-1	4302C033 4302C019 4302C019 43121677 43121677 43121677						

TOSHIBA Single Phase Compressors

Type No.	Part No.	Winding Resistance		Oil Type	Oil Qty ml	Model No.
		Ohms @ 20°C				
		Red-Black	Black-White			
2PS146D5AB02		3.88	5.06	4 GDID	350	RAS-10SA-E-1
KH 15N2-5	43904034	7.4	12.8			RAD-50PDE
KRH 94DA1-4L	43041405	2.93	4.03	4 GSD	430	RAC-10JFE4
KRH 94DA4-4L	43041424	3.97	6.4	4 GSD	430	RAC-10JFE3
KRH 120DAG5-4L	43941018					RAS-20LAHE
PB 190Y-5	43906081	17.5	39.6			RAD-60BDE
PG 330X3F-4LS	43A41506			RB68AF	1100	RAV-134A/AH-PE
PG 350X3F-4LS	43A41507			RB68AF	1100	RAV-164A/AH-PE
PG 460X3F-4MS	43A41508			RB68AF	1400	RAV-264A/AH-PE
PH 70T1-4C	43041142	3.44	6.18	4 GSD	370	RAS-07EA/EAH/UAH
PH 70X1-4D3	43041141	4.47	7.51	4 GSD	370	RAS-07PAH
PH 80X1-4G	43041253	4.55	8.43			RAC-06LW
PH 94T1-4C	43041566	2.76	5.96	4 GSD	370	RAS-09UA
PH 94T1-4C	43041564	2.76	5.96	4 GSD	370	RAS-09EA/EAH/UAH
PH 94X1-4C3	43141005	4.55	8.55			RAV-M200A
PH 94X1-4D3	43041562	4.55	8.55	4 GSD	370	RAS-09PAH
PH 94X1-4G	43041552	4.55	8.55	4 GSD	220	RAC-08EW
PH 94X1-4G1	43041589	4.55	8.55			RAC-08EW-E
PH 94XA4-4K	43041497	4.55	8.55			RAS-20BA
PH 102T1-4C	43T41402	3.88	5.06			RAS-10SA
PH 112X1-4G	43041132	3.36	6	4 GSD	305	RAC-20BW
PH 120T1-4C	43T41400	4.53	8.73	4 GSD	400	RAS-10SAH
PH 120X2-4K	43041506	3.2	4.7	4 GSD	370	RAC-09YH/22EH
PH 120X2-4KU	43041591	3.2	4.7	4 GSD	370	RAC-09EH
PH 142X2L-4L	43041732	2.62	4.83	4 GSD		RAS-22GAH
PH 150X2-4L	43141100	2.2	3.5			RAV-M200A
PH 160T2-4LS	43041762	2.38	3.65	4 GSD	480	RAS-13EA/SA
PH 160X2-4L	43041728	2.1	3.2	4 GSD	455	RAC-12YH/13E/30EH
PH 160X2-4L	43041728	2.2	3.5	4 GSD	455	RAV-M240/241/242A,RAS30BA/13UA
PH 160X2-4LU	43041766	2.1	3.2	4 GSD	455	RAC-12EH
PH 160X2J-4LT	43041731	1.77	2.86	4 GSD	455	RAC-12LE/30GE
PH 170T2-4LS	43041764	2.17	3.79	4 GSD	480	RAS-13EAH/SAH
PH 170X2-4L	43041726	2.2	3.75	4 GSD	455	RAS-13UAH/UAH-G/30SAH
PH 207JA-4	43040507	1.11	2.61	3 GSD	1000	RAV-S450/560HJE,RAV-200AH
PH 230X3-4LS	43041837	1.35	2.7	4 GSD	1000	RAV-S453HE,RAV-132AH
PH 230X3-4LU	43041847	1.35	2.68	4 GSD	700	RAC-18EH/LH
PH 247JA-4	43140216	1.03	2.33	3 GSD	1000	RAV-S455E
PH 250X3-4LS	43041845	1.13	2.3	4 GSD	1000	RAV-180/160A(H)-P
PH 250X3-4LU	43041831	1.35	2.68	4 GSD	600	RAC-45SH
PH 250X3J-4LT	43041820	1.35	2.68	4 GSD	600	RAC-18E/46GE
PH 250X3J-4LT	43041820	0.71	1.41	4 GSD	600	RAV-S457E / RAC-18LE
PH 277JA-4	43040508	1.05	1.74	3 GSD	1000	RAV-S715E
PH 330X3-4MS	43140318	0.77	1.87	4 GSD	1100	RAV-240/260/261/262A(H)-P
PH 330X3J-4MT	43041825	0.76	1.87	4 GSD	700	RAC-24E/24LE/60SE
PRH 70XA3-4M	43041115	4.47	7.51	4 GSD	220	RAC-14UWE
PRH 88XA3-4M	43041243	5.4	8.8	4 GSD	220	RAC-16SW
PRH 155DAJ2-5L	43942022					RAS-30PAHE
PRH 157DAJ2-4LF	43041724	2.1	3.15	4 GSD	500	RAC-30NHE
SB 140Y-5	43040001	24	30.6			RAD-50GDE

Details in Italics are Tentative Specifications

It is not necessary to add oil for extended pipe runs.

TOSHIBA Three Phase Compressors

Type No.	Part No.	Winding Resistance Ohms @ 20°C	Oil Type Suniso	Oil Qty ml	Model No.
HV 990CW-Y12	43141603	Inv 1.49\DOL 2.51	3 GSD	7000	MAR-F/M81HTM8
HV 991CW-Y12	43141606	Inv 1.49\DOL 2.51	3 GSD	7000	MAR-F/M81HTM8-E
HV1200CW-Y12	43141702	Inv 1.49\DOL 2.51	3 GSD	7000	MAR-F/M101HTM8
HV1201CW-Y12	43141705	Inv 1.49\DOL 2.51	3 GSD	7000	MAR-F/M101HTM8-E
MG1300CW-20	43A41504	Inv 1.49\DOL 2.51	RB68AF	7000	MAR-C104M8-PE/MARM/F-104HTM8-PE
MG1300CW-20	43A41504	Inv 1.49\DOL 2.51	RB74AF74VG	7000	MAR-F105HTM8-PE
MG1450CW-21B	43A41510	Inv 1.18\DOL 2.25	RB74AFVG74	7500	MM-A0280 HT/CT
YG1800CW-B1	43A41511	DOL 2.25\DOL 2.25	RB74AFVG74	7500	MM-A0224 HT/CT
YG1700CW-B1	43A41512	DOL 2.25\DOL 2.25	RB74AFVG74	7500	MM-A0224 HX/CT
YG890C-B1	43A41513	DOL 2.25	RB74AFVG74	2000	MM-A0160 HX/CT
YG 460X3F-MS	43A41509		RB68AF	1400	RAV-264A8/AH8-PE
DA421A3FB-23	43041781				MMY-MAP0801/1001/1201FT8
DA421A3FB-23	43041781				MMY-MAP0802/1002/1202FT8
DA351A3FB-23M	43041782				MMY-MAP0501/0601HT8
DA421A3FB-23M	43041781				MMY-MAP0801/1001/1201HT8
YH 277JA	43140213	4.43	3 GSD	1000	RAV-S710/713HE8
YH 330X3-MS	43141302	4.15	4 GSD	1110	RAV-242/262A(H)8-PE
YH 406JA	43140404	2.88	3 GSD	1550	RAV-S1000/1003/1005(H)E8 RAV-360/361/362(H)E8(-PE)
YH 506JA	43140506	2.29	3 GSD	1550	RAV-S1250/1253/1255(H)E8 RAV-460/461/462(H)E8(-PE)
YH 750JA	43140606	1.37			RAV-S1800/2000/640HE8
YH1000JA	43948031	1.05			RAV-S2500HE8
ZR 49K3-TFD	43A41500	3.73	32A	1.55	RAV-363A(H)8-PE
ZR 49KCE-TFD	43A41502		RL32CF	1952	RAV-364A8/AH8-PE
ZR 61K3-TFD	43A41501	2.91	32A	1.85	RAV-463A(H)8-PE
ZR 61KCE-TFD	43A41503		RL32CF	1952	RAV-464A8/AH8-PE

Details in Italics are Tentative Specifications

Note :

1. All three winding resistances should be balanced
2. All resistance readings should be open circuit to earth

TOSHIBA Single Phase Equipment fitted with Three Phase Compressors

Note: Toshiba RAS and RAV Digital Inverter single phase equipment are fitted with three phase compressors

Type No.	Part No.	Winding Resistance Ohms @ 20°C	Oil Type Suniso	Oil Qty ml	Model No.
HV 188X2-S12L	43041537	1.31	4 GSD	370	RAS-22EAHV
HV 210X2-S15L	43041250	1.64	4 GSD	370	RAS-28EAHV
HV 236A1-S15D	43041539	1.26	4 GSD	455	RAS10YAHT/13PAHT,HAS13LAHT
HV 340A2-S12L	43041754	0.62			RAS-18UAHT
HV 340X2-S12L	43041021	0.59	4 GSD	455	RAS-45BAHV
HV 342X2-S12L	43041753	0.59	4 GSD	455	HAS-20LAHV
DA130A1F-23	43041609	0.6 – 1.2			RAV-SM 560AT-E
DA220A2F-20L	43041772	0.6 – 1.2			RAV-SM 800AT-E
DA220A2F-20L	43041772	0.6 – 1.2			RAV-SM1100AT-E
DA420A3F-21M	43041774	0.6 – 1.2			RAV-SM1400AT-E
DA420A3F-21M	43041774	0.6 – 1.2			RAV-1101/1401AT-E
DA220A2F-20L	43041772	0.6 – 1.2			RAV-SP 560/800AT-E
DA420A3F-21M	43041774	0.6 – 1.2			RAV-SP 1100/1400AT-E
DA91A1F-45F	43041612	0.55			RAS-10/13JAVP-E
DA111A1F-20F1	43041631	0.55			RAS-10/13/16EAVP-E
DA111A1F-20F1	43041631				RAS-M14EACV/EAV-E
DA130A1F-25F	43041629				RAS-M18EACV/EAV-E
DA130A1F-21F	43041771				RAS-M18YACV/YAV-E
DA130A1F-21F	43041771	0.2			RAS-3M23YACV-E
DA220A2F-20L	43041772	0.2			RAS-3M26YAV-E
DA220A2F-20L	43041772	0.2			RAS-4M27YACV/YAV-E
DA89X1F-23F	43T41381				RAS-10/13NAV-E
DA130A1F-24F	43T41359				RAS-16NAV-E

Details in Italics are Tentative Specifications

Note :

1. All three winding resistances should be balanced
2. All resistance readings should be open circuit to earth

TOSHIBA Split System Return Air Filters

Model No	Part No.	Qty / Units	Model No.	Part No.	Qty / Units	Model No.	Part No.	Qty / Units
HAS-13LUHT	43480529	2	RAV-361/2CH-PE	43180283	4	RAS-09EK/EKH	43080359	1
HAS-20LUHV			RAV-361/2C-PE	43180284	1	RAS-09UKH/PKH	43080358	1
RAV-1003CHE8	43180253	2	RAV-453CHE	43180253	2	RAS-09UKR	43080347	1
	43180254	2		43180254	1		43989346	1
RAV-1003FHE8	43180238	1	RAV-453KHE	43180272	3	RAS-10SK/SKH-E	43T80001	1
RAV-362FH-E			RAV-160KH-P			RAS-13SK/SKH	43T80002	1
			RAV-180K-P					
RAV-1003UHE8	43480257	1	RAV453LHE(-E)	43180280	2	RAS-10YKHT	43080314	1
RAV-1253UHE8			RAV-162LH-E			RAS-13PKHT		
RAV-1006UE8								
RAV-1256UE8			RAV-453UHE	43480526	1	RAS-13EK/EKH	43080352	2
RAV-103NH-PE	43A80006	1	RAV-713UHE8			RAS-13UKR/UKH		
			RAV-457/8UE					
RAV103TUH-PE	43080392	2	RAV-716/7UE(8)			RAS-18UKHT	43080352	2
RAV-133TUH-PE								
RAV-163TUH-PE			RAV461/2CH-PE	43180283	6	RAS-20BK(W)	43080295	2
RAV133TU-PE			RAV461/2C-PE			RAS-20LKHE	43080153	2
RAV163TU-PE								
RAV-1253CHE8	43180253	4	RAV-713CHE8	43180253	4	RAS-22EKHV(W)	43080220	2
	43180254	1	RAV-200KH	43180272	4	RAS-28EKHV(W)		
			RAV-260KH-P					
RAV-1253FHE8	43180238	1	RAV-240K-P			RAS-30BK/SKH	43080232	2
RAV-462FH-E						RAS-22GKH		
			RAV-713-LHE(-E)	43180280	2			
RAV-130/2UH-PE	43480533	1	RAV-262LH-E			RAS-30GK	43080229	2
RAV-160/2UH-PE								
RAV-260/2UH-PE			RBC-RK162BE	43A80004	2	RAS-30PKHE	43080162	2
RAV-180/2U-PE								
RAV-240/2U-PE			RBC-RK262BE	43A80004	3	RAS-45BKHV	43080275	2
						RAS-13UKHP-E3		2
RAV-132CH-PE	43180283	3	RBC-RK462BE	43A80005	2	RAS-13UKP-ES3		2
RAV-132C-PE						RAS-13UKP-ES4		2
RAV-161/2CH-PE			RBC-U264-PG	41480545	1	RAS-13UKHP-ES3		2
RAV-181/2C-PE						RAS-13UKHP-ES4		2
			RBC-U464-PG	41480546	2	RAS-18UKP-ES3	43T80304 (R)	1
RAV-133KH-PE	43A80008	3					43T80306 (L)	1
			RAV-SM560UT-E	43480010	1	RAS-18UKP-ES4	43T80306 (L)	1
RAV-133NH-PE	43A80007	1	RAV-SM800UT-E				43T80312 (R)	1
RAV-163NK-PE			RAV-SM1100UT-			RAS-18UKHP-ES3	43T80304 (R)	1
RAV263NH-PE			RAV-SM1400UT				43T80306 (L)	1
						RAS-18UKHP-ES4	43T8036 (L)	1
RAV-160BH	43480522	4	RAV-SM561BT	43180311	1		43T80312 (R)	1
			RAV-SM801BT	43180312	1	RAS-24UKP-ES3	43T80304 (R)	1
RAV-160KH(W)-P	43100290	3	RAV-SM1101BT	43180311	2		43T80306 (L)	1
RAV-162KH(W)-PE			RAV-SM1401BT		2	RAS-24UKP-ES4	43T80306 (L)	1
RAV-180K(W)-P							43T80312 (R)	1
RAV-182K(W)-PE			RAV-SM560BT-E	43119422	1	RAS-24UKHP-ES3	43T80304 (R)	1
			RAV-SM800BT-E	43119463	1		43T80306 (L)	1
RAV-163SH-PE	43180284	3				RAS-24UKHP-ES4	43T80306 (L)	1
			RAV-SM-560KRT	43T80014	L		43T80312 (R)	1
RAV-202KH(W)	43100290	4		43T80013	R	RAS-10UKV-E3	43T80301	2
RAV-260KH(W)-P						RAS-10UKV-E4		2
RAV-262KH(W)-PE						RAS-13UKV-E3		2
RAV-240K(W)-PE			RAV-SM560XT	43T80302	2	RAS-13UKV-E4		2
RAV-242K(W)-PE			RAV-SM800XT		2	RAS-16UKV-E		2
RAV203KH-PE	43A80008	4	RAV-SM561CT	43180314		RAS-10NKV-E	43T80310 (L)	1
RAV-263KH-PE			RAV-SM801CT	43180315			43T80311 (R)	1
RAV-243K-PE			RAV-SM1101CT	43180314		RAS-13NKV-E	43T80310 (L)	1
			RAV-SM1401CT	43180315			43T80311 (R)	1
RAV-261/2CH-PE	43180283	2				RAS-16NKV-E	43T80310 (L)	1
RAV-241/2C-PE	43180254	2					43T80311 (R)	1
RAV-263SH-PE	43180283	2						
	43180284	3						
RAV-360/2UH-PE	43480531	2				RAS-M10UKCV-E3	43T80301	2
RAV-460/2UH-PE						RAS-M13UKCV-E3		2
RAV-360/2U-PE						RAS-M16UKCV-E3		2
RAV-460/2U-PE						RAS-M10UKV-E3		2
						RAS-M13UKV-E3		2
						RAS-M16UKV-E3		2

Fault Codes – RAS Series

Do Not turn off the power supply before reading the fault codes, doing so will clear the diagnostic memory. Caution must be taken when removing the access covers as high voltages are present.

Fault diagnosis is available by pressing the check button on the rear of the remote controller.

Note: Fault diagnosis for these systems is only possible when using infrared remote controller type WC-C2YE or WH-C2YE (which may be ordered under part number 43069666)

Code		Code	Fault	System Status	Check
00	Indoor P.C. Board Fault	0C	TA Sensor open circuit	No cooling operation (Heating operation continuously – heat pumps)	Sensor Resistance 20°C = 12.5kΩ, 25°C = 10kΩ
			TA Sensor short circuit	No heating operation – heat pumps (Cooling operation continuously)	Sensor Resistance 20°C = 12.5kΩ, 25°C = 10kΩ
		0d	TC Sensor open circuit	No cooling operation (Heating operation continuously – heat pumps)	Sensor Resistance 20°C = 12.5kΩ, 25°C = 10kΩ
			TC Sensor short circuit	No heating operation – heat pumps (Cooling operation continuously)	Sensor Resistance 20°C = 12.5kΩ, 25°C = 10kΩ
		11	Fan Motor	System Stop	Seized motor Thermal fuse open circuit
		12	PCB Fault	System Stop	Replace PCB
		21	IOL Operation	System Stop	
		13	TC Temp.	Operation Continues	Check TC Sensor
01	Inter. Cable	04	Inter. Cable	System Stop	Cable / CT termination and thermal fuse
		05	Inter Cable.	Operation Continues	No Communication to the outdoor unit.
02	Outdoor PCB	18	TE Sensor Open / Closed circuit	System Stop	Check outdoor TE sensor
		19	TD Sensor Open / Closed circuit	System Stop	Check outdoor TD sensor
03	Other Parts	07	Instantaneous power failure Compressor thermo	Operation Continues	Check Compressor thermo. Check Ref. charge Indoor PCB
		1E	TD > 120°C	System Stop	Check TD Sensor Check Ref. Charge
		09	No change in temp. Of indoor unit	Indoor unit operates	Compressor running not pumping / klixon tripped. For cross wiring.
			Frost Condition	Indoor fan low speed, no outdoor unit operation	Gas charge / pipe blockage. Indoor air flow TC Sensor Cross wiring
		1d	Compressor	System Stop	Compressor windings. Current consumption.

The LEDs on the indoor unit will also flash depending on the type of fault :-

Operation display flashing at 1Hz	Restoration of power after a power cut	N/A
Operation display flashing at 5Hz	TA Sensor fault	0C
Operation display flashing at 5Hz	TC Sensor fault	0d
Operation display flashing at 5Hz	Fan motor fault	11
Operation display flashing at 5Hz	PCB fault	12
Operation and timer display flashing at 5Hz	Interconnecting cable	04
Operation, timer and pre-heat display flashing at 5Hz	No temp change or frost condition	09
Operation, timer and pre-heat display flashing at 5Hz	Compressor	1d













Fault Codes – RAS “N” Series

Do Not turn off the power supply before reading the fault codes, doing so will clear the diagnostic memory. Caution must be taken when removing the access covers as high voltages are present.

Fault codes are displayed through the LEDs flashing at 5 times per second. Note, the green LED will flash once per second when the system is initially powered.

More specific codes may be obtained, while in the fault mode through the wireless controller

1. Press CHK to enter service mode
2. Navigate through TIMER **p q** buttons until all LEDs flash, accompanied by the internal buzzer – compare the displayed code with the table below
3. Press CLR button to clear the existing fault code (controller displays 7F)
Press ON/OFF button to exit service mode.

Initial code/display	Code	Description
01   	0C	TA sensor open or short circuit
	0d	TC sensor open or short circuit
	11	Indoor fan motor problem
	12	Indoor PCB problem
01   	04	Indoor to outdoor communication (includes compressor thermostat)
	05	Indoor to outdoor communication
02   	14	Inverter low voltage or short circuit protection
	16	Compressor position circuit
	17	Compressor current detected during off-cycle
	18	TE or TS sensor open or short circuit
	19	Td sensor open or short circuit
	1A	Outdoor fan motor problem
	1b	TE sensor fault
	1C	Compressor drive circuit
03   	07	Indoor to outdoor communication (includes compressor thermostat)
	08	Indoor heat exchanger changes temperature – but in wrong direction
	1d	Compressor locked rotor current protection
	1E	Compressor - high discharge temperature
	1F	Compressor current remains too high – after current release

Fault Codes – RAV Series

Do Not turn off the power supply before reading the fault codes, doing so may clear the diagnostic memory. Caution must be taken when removing the access covers, as high voltages are present.

Fault diagnosis is available by pressing the check button on the remote controller.

Note: The first number displayed is a code for the number of compressor starts the indoor unit has requested. This number is displayed using the hexadecimal format. Numbers displayed after the start number are fault codes.

Code	Fault	System Status	Check
0C	TA Sensor open circuit	No cooling operation (Heating operation continuously – heat pumps)	Sensor Resistance 20°C = 12.5kΩ, 25°C = 10kΩ
	TA Sensor short circuit	No heating operation – heat pumps (Cooling operation continuously)	Sensor Resistance 20°C = 12.5kΩ, 25°C = 10kΩ
0d	TC Sensor open circuit	Indoor fan stays off in the heating mode	Sensor Resistance 20°C = 12.5kΩ, 25°C = 10kΩ
	TC Sensor short circuit	Outdoor unit simulates high temperature release continually	Sensor Resistance 20°C = 12.5kΩ, 25°C = 10kΩ
04	No communication Outdoor to Indoor	Indoor unit operates – outdoor unit does not	Interconnecting cables / isolator Outdoor transformer (240/12vac) Printed Circuit Board
08	Reverse change temp.	Cooling o/p in Heat mode or Heating o/p in Cool mode	Operation of 4 way valve, energised for heating / TC sensor
09	No change in temp. of indoor unit	Indoor unit operates	Compressor running not pumping / klixon tripped. / For cross wiring.
	Frost Condition	Indoor fan low speed, no outdoor unit operation	Gas charge / pipe blockage. Indoor air flow TC Sensor / For cross wiring
0b	Indoor water level	Indoor unit operates – outdoor unit does not	Lift pump operation. Condensate drain for blockage. Float switch operation – break on rise.
97	LAN com. fault	One zone may not be operating	X&Y terminations and wiring continuity. Indoor PCB
98	Duplicated zone address	Dupl. Addresses Stop	SW02 address set up
99	No communication Indoor to Rem. Con.	System stop.	Interconnecting cables. Indoor is set up as a master. Only one master in a group.
18	TE Sensor open circuit	System stop.	Sensor Resistance 20°C = 12.5kΩ, 25°C = 10kΩ
	TE Sensor short circuit	System stop.	Sensor Resistance 20°C = 12.5kΩ, 25°C = 10kΩ
19	TL or TD Sensor open circuit	System stop.	Sensor Resistance TL 20°C = 12.5kΩ, 25°C = 10kΩ TD 23°C = 53kΩ
	TL or TD Sensor short circuit	System stop.	Sensor Resistance TL 20°C = 12.5kΩ, 25°C = 10kΩ TD 23°C = 53kΩ
20	Low Pressure Trip	System stop.	Change Outdoor PCB (No LP Switch)
21	High Pressure Trip	System stop.	Gas Charge – quantity & quality Pipe blockages Air flows
1E	High Compressor Discharge Temperature	System stop.	Gas Charge – quantity & quality TD sensor Indoor unit air flow
b5	External input display fault or Low level refrigerant leak if RD1 fitted	System stop.	Check connectons on indoor pcb and chech leak detection system if fitted
b6	External interlock display fault or high level refrigerant leak if RD1 fitted	System stop.	Check connectons on indoor pcb and chech leak detection system if fitted
b7	Slave unit in group has fault	Group stop.	Check group controller for faults

Fault Codes – 2 Pipe Super Multi

Do Not turn off the power supply before reading the fault codes, doing so will clear the diagnostic memory. Caution must be taken when removing the access covers, as high voltages are present.

Fault diagnosis is available at three locations within the Air Conditioning system. :-

1. Remote Controller - press the check button
2. Multi Controller - rotate the display switch to position 1
3. Outdoor Unit - see following chart

Remote Controller Press check	
04	No Communication Interface to Inverter
	No Communication Multi C. to Outdoor
	No Communication Indoor to Multi C.
0b	ID water level
0C	TA Sensor Fault
0d	TC Sensor Fault
08	Reverse change temp
09	Frost or no temp change
99	No Communication Indoor to Rem Con

15	Refer to Multi Con	i
	Preheat/Defrost Flash	Æ

1C	Refer to Outdoor	Æ
----	------------------	---

14	Refer to Outdoor	Æ
1d	Refer to Outdoor	Æ
1F	Refer to Outdoor	Æ
18	Refer to Outdoor	Æ
21	Refer to Outdoor	Æ

Multi Controller Switch position 1		
04	No Communication Interface to Inverter	Æ
	No communication Multi C. to Outdoor	

88	M/C doesn't recognise outdoor capacity	Æ
80	Th(A) Sensor Fault	Ä
81	Th(B) Sensor Fault	Ä
82	Th(C) Sensor Fault	Ä
83	Th(D) Sensor Fault	Ä
84	Th(X) Sensor Fault	Ä
0b	M/C water level	Ä
89	ID codes set too high	Ä
	ID codes set to zero	Ä

1C	Refer to Outdoor	Æ
----	------------------	---

14	Refer to Outdoor	Æ
1d	Refer to Outdoor	Æ
1F	Refer to Outdoor	Æ
18	Refer to Outdoor	Æ
21	Refer to Outdoor	Æ

Outdoor Unit Switch position 0		
LED 5 off LED 6 on	No Communication Interface to Inverter	Æ

Display Switch set to 8 (If lit...)		
LED 1	Th(A) Sensor Fault	Æ
LED 2	Th(B) Sensor Fault	Æ
LED 3	Th(C) Sensor Fault	Æ
LED 4	Th(D) Sensor Fault	Æ
LED 5	Th(X) Sensor Fault	Æ
	M/C water level	Æ
LED 6	ID codes set too high	Æ
LED 7	M/C 1 Sensor Fault	Æ
LED 8	M/C 2 Sensor Fault	Æ

Display Switch set to 3 (If lit...)		
LED 1	ThD1 Sensor Fault	Æ
LED 2	ThD2 Sensor Fault	Æ
LED 3	ThS Sensor Fault	Æ
LED 4	HP Trip, by sensor	Æ
LED 5	Pd Sensor Fault	Æ
LED 6	Discharge Pipe >130°C	Æ
LED 7	Suction Pipe > 40°C	Æ
LED 8	Low Pressure Trip	Æ

Inv. PCB SW01 set to Off/Off		
® i i i	Low Inverter Voltage	Æ
i ® i i	High Inverter dc Current	Æ
i i ® i	High Inverter ac Current	Æ
i i i ®	ThE Sensor Fault	Æ
i i i ®	Inverter HP Trip	Æ
	Inv. Comp. overheat	Æ
	Phase Rotation / DOL HP Trip / Overload Trip / DOL Comp. overheat	Æ

®=LED Flashing i =LED Lit

Fault Codes – 3 Pipe Super Multi

Do Not turn off the power supply before reading the fault codes, doing so will clear the diagnostic memory. Caution must be taken when removing the access covers, as high voltages are present.

Fault diagnosis is available at three locations within the Air Conditioning system. :-

1. Remote Controller - press the check button
2. Multi Controller - rotate the display switch to position 1
3. Outdoor Unit - see following chart

Remote Controller Press check	
04	No Communication Interface to Inverter
	No Communication Multi C. to Outdoor
	No Communication Indoor to Multi C.
0b	ID water level
0C	TA Sensor Fault
0d	TC Sensor Fault
08	Reverse change temp
09	Frost or no temp change
99	No Communication Indoor to Rem Con

15	Refer to Multi Con Preheat/Defrost Flash
----	---

1C	Refer to Outdoor
----	------------------

14	Refer to Outdoor
1d	Refer to Outdoor
1F	Refer to Outdoor
21	Refer to Outdoor

Multi Controller Switch position 1	
04	No Communication Interface to Inverter
	No communication Multi C. to Outdoor

88	M/C doesn't recognise outdoor capacity
80	Th(A) Sensor Fault
81	Th(B) Sensor Fault
82	Th(C) Sensor Fault
83	Th(D) Sensor Fault
84	Th(X) Sensor Fault
0b	M/C water level
89	ID codes set too high ID codes set to zero

1C	Refer to Outdoor
----	------------------

14	Refer to Outdoor
1d	Refer to Outdoor
1F	Refer to Outdoor
21	Refer to Outdoor

Outdoor Unit Switch positions 2 & 0	
04	No Communication Interface to Inverter

80	Th(A) Sensor Fault
81	Th(B) Sensor Fault
82	Th(C) Sensor Fault
83	Th(D) Sensor Fault
84	Th(X) Sensor Fault
0b	M/C water level
89	ID codes set too high

A0	ThD1 Sensor Fault
A1	ThD2 Sensor Fault
A2	ThS Sensor Fault
A4	ThO Sensor Fault
A5	ThE Sensor Fault
A6	Discharge Pipe > 130°C
A7	Suction Pipe > 40°C
AA	Pressure Sensor Fault
AE	Low Pressure Trip
14	Low Inverter Voltage
1d	High Inverter dc Current
1F	High Inverter ac Current
21	Inverter HP Trip Inv. Comp. overheat
Ad	Phase Rotation / DOL HP Trip / Overload Trip / DOL Comp. overheat

Fault Codes – 3 Pipe SMI

Do Not turn off the power supply before reading the fault codes, doing so will clear the diagnostic memory. Caution must be taken when removing the access covers, as high voltages are present.

Fault diagnosis is available at three locations within the Air Conditioning system. :-

1. Remote Controller - press the check button
2. Multi Controller - rotate the display switch to position 1
3. Outdoor Unit - see following chart

Remote Controller Press Check	
04	No Communication Between Interface and IPDU
	No Communication between M/C and O/D
	No Communication between I/D and M/C
0b	Drain pump fault I/D
0C	TA Sensor fault
0d	TC Sensor fault
08	Reverse TC temp. change
09	No TC temp. change
11	I/D Fan Motor short circuit
12	I/D PCB short circuit
b5	External input display fault
	Low level refrigerant leak if RD1 fitted
b6	External interlock display fault
	High level refrigerant leak if RD1 fitted
97	Central management comms. Short circuit
98	Central management address set-up fault
99	No communication I/D to R/C

15	Refer to M/C
----	--------------

1C	Refer to O/D
----	--------------

Multi Controller Switch Position 1	
04	No Communication between interface PCB and IPDU
	No Communication between M/C and O/D

8A	Multi Controller PCB error
88	Communication error between O/D and M/C
80	ThA sensor fault
81	ThB sensor fault
82	ThC sensor fault
83	ThD sensor fault
84	ThX sensor fault
0b	Drain pump fault M/C
89	I/D units capacity too high or set at 0

1C	Refer to O/D
----	--------------

Outdoor Unit Switch Position 2 & 0	
No Communication between Interface PCB and IPDU	

80	ThA sensor fault
81	ThB sensor fault
82	ThC sensor fault
83	ThD sensor fault
84	ThX sensor fault
0b	Drain pump fault M/C
89	Over Capacity

14	Refer to O/D
17	Refer to O/D
21	Refer to O/D
1d	Refer to O/D
1F	Refer to O/D
d3	Refer to O/D
dA	Refer to O/D

14	Refer to O/D
17	Refer to O/D
21	Refer to O/D
1d	Refer to O/D
1F	Refer to O/D
d3	Refer to O/D
dA	Refer to O/D

08	Four way valve alarm
A0	Discharge temp. sensor TD1 short circuit
A1	Discharge temp. sensor TD2 short circuit
A2	Suction temp. sensor TS short circuit
A4	External air sensor Th0 short circuit
A5	O/D heat exchanger sensor TE short circuit
A6	Discharge temp TD1 high temp. > 130°C
A7	Suction temp. TS high temp. > 40°C
AA	Pressure sensor Pd short circuit
Ad	DOL compressor fault
AE	Low pressure < 3 psig – 0.21 Bar
AF	O/D power phase miss-wire
1C	Extension IC EPROM short circuit
14	G-Tr short circuit protection
17	Current detection circuit
21	High pressure switch circuit > 425 psig – 29 Bar
1d	Compressor error
1F	Inverter malfunction
d3	TH sensor circuit – inverter micro. IPDU
dA	Heat sink overheat protection IPDU

Fault Codes – 2 Pipe Modular Multi

Do Not turn off the power supply before reading the fault codes, doing so will clear the diagnostic memory. Caution must be taken when removing the access covers, as high voltages are present.

Fault diagnosis is available at three locations within the Air Conditioning system. :-

1. Remote Controller - press the check button (if installed)
2. Central Controller – press the check button (if installed)
3. Outdoor Unit – Inv & Fix switch positions 1 - 1 - 1

Code	PCB	Area	Condition	Criteria
04	IFACE	IFACE to INV	Communication failure	
08	IN	TC1 and TC2 coil sensors	Indoor heat exchange changes temperature but in wrong direction	
0C	IN	TA air temperature sensor	OC/SC	
0b	IN	Float switch circuit	OC	
11	IN	Fan motor	Short circuit	
12	IN	PCB	EEPROM failure	
14	INV	DC current sensor	INV compressor or transistor SC. Sensor OC	
17	INV	DC current sensor	INV compressor current detected during off cycle.	
18	IFACE	TE1 defrost sensor	OC/SC	
1C	IFACE	PCB	EEPROM failure	
1d	INV	DC current sensor	INV compressor overload	> 1.5 times full load current
1F	INV	DC current sensor	Excessive current detected after current release	
21	INV	INV compressor	HP switch or klixon	> 363 psig – 25 Bar
22	IFACE	Pd sensor	Excessive pressure	> 406 psig – 28 Bar
87	IFACE	Input Phase	Missing phase	
89	IFACE	IN capacity settings	Too high	> 135% outdoor unit
8d	IFACE	Outdoor units - number of	Has fallen since last set up	
8E	IFACE	Outdoor units - number of	Is too high	> 5
8F	IFACE	FIX unit address	Duplicated	When manually set
93	IN	TC1 gas sensor	OC/SC	
94	IN	TC2 liquid sensor	OC/SC	
95	IFACE	PQ	Communication failure	No INV outdoor unit
96	IFACE	IN units - number of	Too many	> 40
97	Central	XY	Communication failure	
98	Central	XY	Duplicated addresses	
99	Remote	ABC	Communication failure	
9A	IN	TC1 gas sensor	Unauthorized temperature change	Changed by > 5°C after 15 minutes operation
9F	IN	TC1 gas sensor and TC2 liquid sensor	Insufficient performance	Changed by < 5°C after 60 minutes operation
A0	IFACE	TD1 discharge sensor	OC/SC	
A1	IFACE	TD2 discharge sensor	OC/SC	
A2	IFACE	TS1 suction sensor	OC/SC	
A6	IFACE	TD1 discharge sensor	High discharge temperature	> 130°C 3 times
A7	IFACE	TS1 suction sensor	High suction temperature	> 60°C for 10 minutes, 3 times
AA	IFACE	Pd pressure sensor	OC	
Ab	IFACE	Pd and Ps pressure sensors	OC or crossed	
AE	IFACE	TD1 discharge sensor	High discharge temperature (low load condition)	> 110°C, 3 times
AF	IFACE	Phase rotation	Incorrect	

Code	PCB	Area	Condition	Criteria
b4	IFACE	Ps sensor	Suction pressure too high during operation	OC or < 138 psig – 9.5 Bar
b5	IN	CN17	Indoor unit emergency circuit	Resistive connection
b6	IN	CN17	Indoor unit emergency circuit	SC
b7	Central	Fault in connected group	Check local controller	
b9	IN	Pressure sensor	OC	
bb	IFACE	TD2 discharge sensor	High discharge temperature	> 130°C 3 times
bd	IFACE	TD2, Ps, Pd	FIX compressor contactor fault	Operation detected during off cycle
bE	IFACE	Ps sensor	Low pressure	< 3 psig – 0.21 Bar
cF	IN	Main and relay PCBs	Communication failure	
d1	IFACE	INV outdoor units	Duplicated within a system	
d2	IFACE	FIX unit fault	Press SW04 for several seconds	Fan of outdoor unit runs
d3	IFACE	TH inverter overheat sensor	OC/SC	
d4	IFACE	TK1 oil level sensor primary side	OC/SC	
d5	IFACE	TK2 oil level sensor secondary side	OC/SC	
d6	IFACE	TK3 oil level sensor	OC/SC	
d7	IFACE	TK1, 2, 3	Oil level low	> 2 hours
d8	IFACE	TK1 oil level sensor primary side	No oil flow detected	No temp change during oil level management
d9	IFACE	TK2 oil level sensor secondary side	No oil flow detected	No temp change during oil level management
dA	INV	IGBT overheating		
db	IFACE	TK1 and TK2	No oil flow detected	No temp change during oil level management
dC	IFACE	TK1	High oil temperature	> 50°C
dd	IFACE	FIX outdoor unit	Operation detected during off cycle	
dE	IFACE	IN unit	Automatic addressing failure	
dF	IFACE	Outdoor unit	Automatic addressing failure	
E1	IFACE	FIX compressor 1	HP switch, klixon or overload relay	Pd is > 363 psig – 25 Bar
E5	IFACE	INV compressor	HP switch or klixon	Pd is < 363 psig– 25 Bar
E6	IFACE	FIX compressor 1	HP switch, klixon or overload relay	Pd is < 363 psig– 25 Bar
Eb	IFACE	b6 code received from IN unit		
F0	IFACE	FIX compressor 2	HP switch, klixon or overload relay	Pd is > 363 psig– 25 Bar
F1	IFACE	FIX compressor 2	HP switch, klixon or overload relay	Pd is < 363 psig– 25 Bar

Fault Codes [RAV-SM / RAV-SP](#)

Fault codes are displayed directly on wired remote controller – to access the service history:

- Ø Press CHECK and SET for 4 seconds
- Ø Scroll through stored codes using the TEMP set buttons
- Ø Press CHECK to cancel service history
- Ø Press CLEAR to delete codes
- Ø Up to 4 Codes can be stored

Code	Description
E01	Controller (local or network) receives no communication from a master indoor unit- could include that master is turned off. Also check that there is a master controller
E02	Local controller failure (unable to transmit)
E03	Master indoor unit receives no data to A-B. Often appears as an E01 fault code
E04	Indoor unit (except twin slave) receives no communication from outdoor unit; can include klixon on 560 Digital Inverter split system – checked by measuring 280VDC across outdoor unit capacitors
E08	Duplicated indoor address
E09	2 local controller on a group – both configured as masters
E10	Indoor PCB failure
E18	Communication failure between master indoor unit and slave
F01	Indoor TCJ sensor error
F02	Indoor TC2 sensor error
F04	TD1 sensor error
F06	TE1 sensor error
F08	TO sensor error
F10	Indoor TA sensor error
F29	Indoor PCB failure
H01	Inverter compressor over current detected
H02	Master outdoor unit over current detected shortly after start up
H03	Current detected on master outdoor unit whilst idle
H06	Low pressure detected by Ps sensor (0.02Mpa)
L03	Duplicated master indoor units in a group
L07	Indoor in a group previously addressed as a single unit – check addressing
L08	Indoor address not set
L09	Indoor unit capacity not set
L29	IPDU error (number of detected IPDU units is reduced)
L30	Input on CN80 circuit for 1 minute
L31	Outdoor PCB error
P01	Indoor fan motor error
P03	High discharge temperature (TD1 exceeded 115°C)
P04	High pressure switch activated (Detected by high TE temp on Digital Inverter)
P07	Heat sink overheat
P10	Float switch activated
P12	Indoor fan motor error – detected by feedback circuit
P19	Wrong change in temperature (4 way valve error)
P22	Outdoor fan IPDU error
P26	Giant Transistor short circuit
P29	Compressor error detected by feedback circuit
P31	Indoor PCB error

Error by TCC-Link central controller

Code	Description
C05	Sending error in TCC-Link central control device
C06	Receiving error in TCC-Link central control device
C12	Batch alarm for general purpose equipment control interface
P30	Group control follower unit error/duplicated central control addresses

Fault Codes [SMMS / SHRM](#)

Remote controller AMT21 / 31, will automatically display fault codes at the bottom left of the LCD display. On the outdoor unit fault codes are obtained by the three rotary switches being in the 1-1-1 positions.

IPDU: Intelligent Power Drive Unit
 O: Operation T: Timer R: Ready F: Flash
i : LED ON **R**: LED Flashing **I** : LED OFF
 Alt: Flashing is alternately when there are two flashing LED.
 Sim: Simultaneous flashing when there are two flashing LED.

Check Code				Wireless Remote				Check Code	Judging Device
Main TCC Remote	Outdoor 7 segment display		AI Central controller	Sensor block display					
		Sub code		O	T	R	F		
E01	---	---	---	R	I	I		Communication error between indoor unit and remote controller (Detected at remote controller)	Remote Controller
E02	---	---	---	R	I	I		Sending error of remote controller	Remote Controller
E03	---	---	97	R	I	I		Communication error between indoor unit and remote controller (Detected indoor)	Indoor
E04	---	---	04	I	I	R		Communication circuit error between indoor and outdoor units (Detected indoor)	Indoor
E06	E06	No. of indoor units in which sensor has been normally received	04	I	I	R		Decrease of No. of indoor units	I/F
---	E07	---	---	I	I	R		Communication circuit error of indoor and outdoor units (Detected outdoor)	I/F
E08	E08	Duplicated indoor address	96	R	I	I		Duplicated indoor address	Indoor / I/F
E09	---	---	99	R	I	I		Duplicated master remote controllers	Remote controller
E10	---	---	CF	R	I	I		Communication error in indoor PCB's ass'y	Indoor
E12	E12	01: Indoor / Outdoor communication 02: Communication between outdoor units	42	R	I	I		Automatic address start error	I/F
E15	E15	---	42	I	I	R		No indoor automatic address	I/F
E16	E16	00: Over capacity 01: No. of connected units	89	I	I	R		No. of indoor units / Over capacity	I/F
E18	---	---	97 / 99	R	I	I		Communication error between indoor header and follower units	Indoor
E19	E19	00: No. header units 02: Two or more header units	96	I	I	R		Outdoor header units quantity error	I/F
E20	E20	01: Outdoor of other line connected 02: Indoor of other line connected	42	I	I	R		Other line connected during automatic address	I/F
E23	E23	---	15	I	I	R		Sending error in communication between outdoor units	I/F
E25	E25	---	15	I	I	R		Duplicated follower outdoor unit addresses	I/F
E26	E26	No. of outdoor units which received signal normally	15	I	I	R		Decrease of No. of connected outdoor units	I/F
E28	E28	Detected outdoor unit number	d2	I	I	R		Outdoor follower error	I/F
E31	E31	01: IPDU 1 error 02: IPDU 2 error 03: IPDU 1, 2 error 04: Fan IPDU error 05: IPDU 1 + Fan IPDU error 06: IPDU 2 + Fan IPDU error 07: All IPDU error	CF	I	I	R		IPDU communication error	I/F
F01	---	---	0F	R	R	I	Alt	Indoor TCJ (Coil) sensor error	Indoor
F02	---	---	0d	R	R	I	Alt	Indoor TC2 (Coil) sensor error	Indoor
F03	---	---	93	R	R	I	Alt	Indoor TC1 (Coil) sensor error	Indoor
F04	F04	---	19	R	R	i	Alt	Outdoor TD1 (Discharge) sensor error	I/F
F05	F05	---	A1	R	R	i	Alt	Outdoor TD2 (Discharge) sensor error	I/F
F06	F06	---	18	R	R	i	Alt	Outdoor TE1 () sensor error	I/F
F07	F07	---	18	R	R	i	Alt	Outdoor TL () sensor error	I/F
F08	F08	---	1b	R	R	i	Alt	Outdoor T0 (Ambient) sensor error	I/F

Check Code			Wireless Remote				Check Code	Judging Device	
Main TCC Remote	Outdoor 7 segment display		AI Central controller	Sensor block display					
		Sub code		O	T	R			F
F10	---	---	0C	R	R	I	Alt	Indoor TA (Return Air) sensor error	Indoor
F12	F12	---	A2	R	R	i	Alt	Outdoor TS1 (Suction) sensor error	I/F
F13	F13	01: Compressor 1 side 02: Compressor 2 side	43	R	R	i	Alt	Outdoor TH (IPDU) sensor error	IPDU
F15	F15	---	18	R	R	i	Alt	Outdoor temp. sensors misconnected (TE, TL)	I/F
F16	F16	---	43	R	R	i	Alt	Outdoor pressure sensors misconnected (Pd, Ps)	I/F
F23	F23	---	43	R	R	i	Alt	Outdoor Ps (pressure) sensor error	I/F
F24	F24	---	43	R	R	i	Alt	Outdoor Pd (pressure) sensor error	I/F
F29	---	---	12	R	R	I	Sim	Indoor other error	Indoor
F31	F31	---	1C	R	R	i	Sim	Outdoor EPROM error	I/F
H01	H01	01: Compressor 1 side 02: Compressor 2 side	IF	I	R	I		Compressor breakdown	IPDU
H02	H02	01: Compressor 1 side 02: Compressor 2 side	1d	I	R	I		Magnetic switch (contactor) error Over current relay operation Compressor error (Lock)	MG-SW Over current relay IPDU
H03	H03	01: Compressor 1 side 02: Compressor 2 side	17	I	R	I		Current detection circuit system error	IPDU
H04	H04	---	44	I	R	I		Compressor 1 case thermo operation	I/F
H06	H06	---	20	I	R	I		Low pressure protection operation	I/F
H07	H07	---	d7	I	R	I		Low oil level protection detected	I/F
H08	H08	01: TK1 sensor error 02: TK2 sensor error 03: TK3 sensor error 04: TK4 sensor error	d4	I	R	I		Oil level detection temperature sensor error	I/F
H14	H14	---	44	I	R	I		Compressor 2 case thermo operation	I/F
H16	H16	01: TK1 oil circuit system error 02: TK2 oil circuit system error 03: TK3 oil circuit system error 04: TK4 oil circuit system error	d7	I	R	I		Oil level detection circuit error Magnetic switch (contactor) error Over current relay operation	I/F MG-SW Over current relay
L03	L03	---	96	R	I	R	Sim	Duplicated indoor header units	Indoor
L04	L04	---	96	R	i	R	Sim	Duplicated outdoor line address	I/F
L05	L05	---	96	R	I	R	Sim	Duplicated indoor units with priority (Displayed on indoor unit with priority)	I/F
L06	L06	No. of indoor units with priority	96	R	I	R	Sim	Duplicated indoor units with priority (Displayed in unit other than indoor unit with priority)	I/F
L07	---	---	99	R	I	R	Sim	Group line in individual indoor unit	Indoor
L08	L08	---	99	R	I	R	Sim	Indoor group / address unset	Indoor I/F
L09	---	---	46	R	I	R	Sim	Indoor capacity unset	Indoor
L10	L10	---	88	R	i	R	Sim	Outdoor capacity unset	I/F
L17	L17	---	46	R	i	R	Sim	Inconsistency error of outdoor units	I/F
L18	L18	---	8A	R	R	R	Sim	FS unit error	FS unit
L20	---	---	98	R	i	R	Sim	Duplicated central controller addresses	AI-NET Indoor
L28	L28	---	46	R	i	R	Sim	No. of connected outdoor units overcapacity	I/F
L29	L29	01: IPDU1 error 02: IPDU2 error 03: IPDU3 error 04: Fan IPDU error 05: IPDU1 + Fan IPDU error 06: IPDU2 + Fan IPDU error 07: All IPDU error	CF	R	i	R	Sim	No. of IPDU error	I/F
L30	L30	Detected indoor address	b6	R	i	R	Sim	Auxiliary interlock in indoor unit	Indoor
---	L31	---	---	--	--	--		IC error	I/F

Check Code				Wireless Remote				Check Code	Judging Device
Main TCC Remote	Outdoor 7 segment display		AI Central controller	Sensor block display					
		Sub code		O	T	R	F		
P01	---	---	11	I	R	R	Alt	Indoor fan motor error	Indoor
P03	P03	---	1E	R	I	R	Alt	Discharge temperature TD1 error	I/F
P04	P04	01: Compressor 1 side 02: Compressor 2 side	21	R	I	R	Alt	High pressure switch detection error	IPDU
P05	P05	01: Phase-missing detection 02: Phase order error	AF	R	I	R	Alt	Phase-missing detection / Phase order error	I/F
P07	P07	01: Compressor 1 side 02: Compressor 2 side	1C	R	I	R	Alt	Heat sink overheat error	IPDU I/F
P10	P10	Detected indoor address	0b	I	R	R	Alt	Indoor overflow error	Indoor
P12	---	---	11	I	R	R	Alt	Indoor fan motor error	Indoor
P13	P13	---	47	I	R	R	Alt	Outdoor liquid back detection error	I/F
P15	P15	01: TS condition 02: TD condition	AE	R	I	R	Alt	Gas leak detection	I/F
P17	P17	---	bb	R	I	R	Alt	Discharge temperature TD2 error	I/F
P19	P19	Detected outdoor unit number	08	R	I	R	Alt	4-Way valve inverse error	I/F
P20	P20	---	22	R	I	R	Alt	High pressure protection operation	I/F
P22	P22	0_: IGBT short 1_: Fan motor position detective circuit error 3_: Fan motor error C_: TH sensor temp. error (Heat sink overheat) D_: TH sensor error E_: Vdc output error	1A	R	I	R	Alt	Outdoor fan IPDU error	Fan IPDU
P26	P26	01: Compressor 1 side 02: Compressor 2 side	14	R	I	R	Alt	G-TR short circuit protection error	IPDU
P29	P29	01: Compressor 1 side 02: Compressor 2 side	16	R	I	R	Alt	Compressor position detective circuit system error	IPDU
P31	---	---	47	R	I	R	Alt	Other indoor unit error (Group follower unit error)	Indoor
---	---	---	b7	By alarm device			Alt	Error in indoor group	AI-NET
---	---	---	97	---				AI-NET communication system error	AI-NET
---	---	---	99	---				Duplicated network adaptors / addresses	AI-NET

Error detected by TCC-Link central control device

Check Code				Wireless Remote				Check Code Name	Judging Device
Central control device	Outdoor 7 segment display		AI Central controller	Sensor block display					
		Auxiliary code		O	T	R	F		
C05	---	---	---	---				Sending error in TCC-Link central control device	TCC-LINK
C06	---	---	---	---				Receiving error in TCC-Link central control device	TCC-LINK
C12	---	---	---	---				Batch alarm of general purpose equipment control interface	HA control interface I/F
P30	Differs according to error contents of unit with occurrence of alarm						Group control follower unit error	TCC-LINK	
	---	---	(L20 is displayed)				Duplicated central control addresses		

SMMS / SHRM Data Display

SW1	W2	SW3		SW1	SW2	SW3	
1	1	1	Fault codes	1	8	2	TE sensor data
1	1	2	Discharge pressure (Mpag)	1	8	3	Oil equalisation control
1	1	3	Refrigerant (R407C / R410A)	1	9	1	Reversing valve status (1=on, 0=off)
1	1	16	Last error code of header unit	1	9	2	TL sensor data
1	2	2	Suction pressure (Mpag)	1	9	3	Oil equalisation request
1	2	3	System capacity	1	10	1	SV2 / SV5 valve status (1=on, 0=off)
1	3	1	Operating mode C=cool, H=heat, J=defrost	1	10	2	TO sensor data
1	3	2	Liquid line pressure (Mpag)	1	10	3	Refrigerant recovery operation (C1 or H1)
1	3	3	Number of outdoor units	1	11	1	SV3A / 3B / 3C / 3D valve status (1=on, 0=off)
1	4	1	Outdoor unit size (HP)	1	11	2	TK1 sensor data
1	4	2	TD1 sensor data	1	11	3	Automatic addressing
1	4	3	Number of indoor units (0-48) Plus No. of units in cooling	1	12	1	SV41 / SV42 valve status (1=on, 0=off)
1	5	1	Compressor speed	1	12	2	TK2 sensor data
1	5	2	TD2 sensor data	1	12	3	Demand operation
1	5	3	Number of indoor units (0-48) Plus No. of units in heating	1	13	1	SV11 / SV12 valve status (1=on, 0=off)
1	6	1	Outdoor fan speed	1	13	2	TK3 sensor data
1	6	2	TS1 sensor data	1	13	3	Operations (h=heating priority, c=cooling priority, H=heating only, C=Cooling only, n=priority on No. of indoor units, U=prioritised indoor unit, I=batch control ON, O=batch control OFF)
1	6	3	Compressor release level (Hex)	1	14	1	PMV1/PMV2 status
1	7	1	Compressor back-up status	1	14	2	TK4 sensor data
1	7	2	TS2 sensor data	1	14	3	Option control
1	7	3	Compressor release	1	16	1	Oil level check for both circuits (0=good, 1 or 2=shortage, A to D TK1 to TK4 sensor error)
2	1	1	Circuit test – cooling	2	*	4	Outdoor fan check 1 high range of speeds LED's show (16-31)
2	1	2	Clearing system address	2	*	5	Outdoor fan check 2 low range of speeds LED's show (00-15)
2	1	3	Solenoid check SV2 / SV3E	2	*	15	Temporary outdoor temperature setting – LED's show selected temperature
2	2	1	Circuit test – heating	3	1	*	Slave outdoor unit fault code
2	2	2	Clearing central addresses	3	2	*	Slave outdoor unit compressor type
2	2	3	Solenoid check SV5 / SV3E	3	3	*	Slave outdoor capacity
2	3	1	Open/close PMV's (FF=open, 00=closed)	3	4	*	Slave outdoor unit compressor ½ status (1=on)
2	3	3	Solenoid check SV41, SV42 & SV3E	3	5	*	Slave outdoor unit fan speed (0 to 31)
2	4	1	Remote control identification function	3	6	*	Slave outdoor unit release signal (1=release)
2	4	3	Solenoid check SV3A / SV3E	3	7	*	Slave outdoor unit oil level (L=low)
2	5	1	System test – cooling, when under way, press SW04 to scroll through, Suction pressure and temperature, discharge pressure and temperature plus sub-cooled liquid temperature	4	*	*	Indoor unit communication check (1=good)
2	5	3	Solenoid check SV3b / SV3E	5	*	*	Indoor unit fault code
2	6	1	System test - heating, when under way, press SW04 to scroll through, Suction pressure and temperature, discharge pressure and temperature plus sub-cooled liquid temperature	6	*	*	Indoor unit capacity (HP)
2	6	3	Solenoid check SV3C / SV3E	7	*	*	Indoor unit demand
2	7	1	Start indoor units to remote controller setting	8	*	*	Indoor unit PMV position
2	7	3	Solenoid check SV3D / SV3E	9	*	*	Indoor unit TA sensor data (Hex)
2	8	3	Solenoid check SV3E forced off	10	*	*	Indoor unit TF sensor data (Hex)
2	9	3	Solenoid check SV3A/SV3B/SV3C	11	*	*	Indoor unit TCJ sensor data (Hex)
2	10	3	Solenoid check SV3E	12	*	*	Indoor unit TC1 sensor data (Hex)
2	11	1	Pump down function	13	*	*	Indoor unit TC2 sensor data (Hex)
2	14	2	Adding additional indoor units	16	*	*	Group master (only) indoor unit – runs to local settings
2	16	1	Error clearing function	Notes 1, 1Mpag = 10 Barg. 2, * slave outdoor unit functions – outdoor unit number is selected (1-3) 3, ** Indoor unit function – indoor unit number is selected (1* = 1 to 16, 2* = 17 to 32, 3* = 33 to 48)			
2	16	3	Solenoid check – all valves				

Super Modular Multi (SMMS / SHRM) Switch Positions

Priority mode (SMMS Only).

Factory setting - Heating priority, this can be modified to Cooling priority via "Dip switch" SW11 bits 1 & 2

In addition to above priority is factory set at "Any one indoor unit" this can be modified to Percentage, i.e. 60% of units requiring a mode, or Set to One SPECIFIC indoor unit.

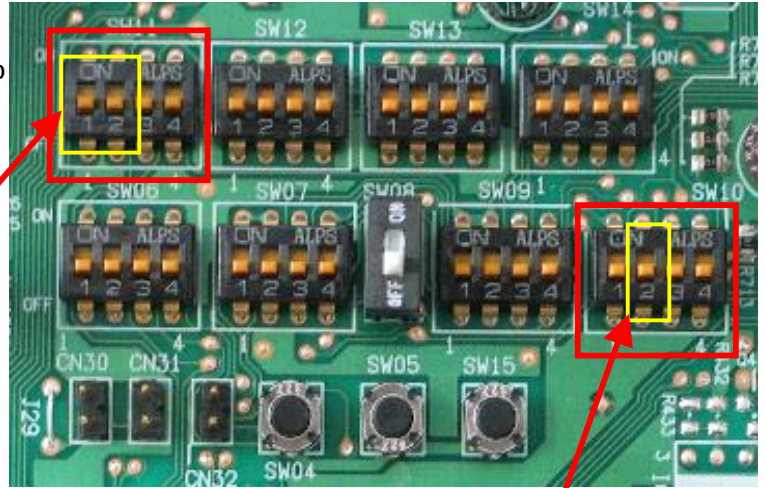

SW11		Operation
Bit 1	Bit 2	
OFF	OFF	Heating priority (Factory setting)
ON	OFF	Cooling priority
OFF	ON	Percentage (60%)
ON	ON	Specific indoor unit

Note; On specific indoor unit setup, it is necessary to set up the specific indoor unit, via remote controller (AMT21/31) Configuration menu "04" please refer to configuration settings on page 54.

High static fan option (SMMS / SHRM)

Factory setting - 15Pa, this can be increased to 35Pa via "Dip switch" SW10 bit 2 – ON = 35Pa

Compressor backup setting

In the event of a compressor error it is possible to electronically remove the affected compressor allowing the second compressor to operate normally, this is achieved via "Dip switch" SW06. Turn OFF the power to the system, set up "Dip switch" SW06 "Bits 1 to 4" as per the chart.

	SW06			
	Bit1	Bit 2	Bit 3	Bit 4
Factory setting	OFF	OFF	OFF	OFF
No 1 Comp. Defective	ON	OFF	OFF	OFF
No 2 Comp. Defective	OFF	ON	OFF	OFF

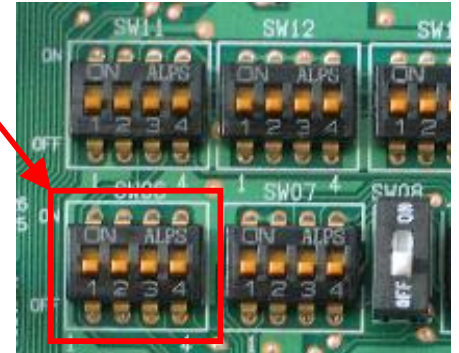

Modular Multi Switch Positions

SW3	SW2	SW1		SW3	SW2	SW1	
1	1	1	Check Codes	2	1	1	Discharge Pressure (MPag)
1	2	1	Compressor Type	2	2	1	Suction Pressure (MPag)
1	3	1	Operation Mode	2	3	1	TD1 discharge sensor
1	4	1	O/D Capacity	2	4	1	TD2 discharge sensor
1	5	1	Compressor Status	2	5	1	TS suction sensor
1	6	1	O/D Fan Operation	2	6	1	TE O/D coil sensor
1	7	1	Compressor Backup	2	8	1	TK1 sensor
1	9 - 13	1	Control Valve Output	2	9	1	TK2 sensor
1	14-15	1	PMV Position	2	10	1	TK3 sensor
1	16	1	Oil Management				
3	1	1	Refrigerant type	2	1	2	Solenoid test SV2
3	2	1	O/D capacity HP	2	2	2	Solenoid test SV41 & 42
3	3	1	No. of connected O/D units	2	3	2	Solenoid test SV3A
3	4	1	No. of connected I/D units	2	4	2	Solenoid test SV3B
3	5	1	No. of I/D units operating	2	5	2	Solenoid test SV3C
3	11	1	Automatic addressing	2	6	2	Solenoid test SV3A, B, C
				2	16	2	All valves
3	1	2	Outdoor fan test	Press SW04			
Press SW04 as SW02 is increased fan will slow down							
1	5	2	100% Cooling demand ALL I/D units. Press SW04 to activate and SW05 To deactivate				
1	7	2	I/D units ON / OFF Press SW04 Start, Press SW05 Stop				
1	4	2	All connected local controllers will display (STANDBY) Press SW04 to start				
1	3	2	All indoor PMV's will be opened for 2 minutes. Press SW04 to start				
1	16	1	Oil Level Test. Press SW04 to start. Results A0 Good – A1 Low oil – A2 TK1 error – A3 Block management circuit – A4 TK2 error				
Indoor PMV operation			Mode Priority				
CN33	CN32	PMV Full Open / Full Close Function	<u>Heat Priority</u> (Factory set)			<u>Cool Priority</u>	
Open	Open	Normal operation	1off - 2off - 3off - 4off			1off - 2on – 3off - 4off	
Open	Short	Fully Open					
Short	Open	Fully Closed	<u>Indoor Unit Associated with Network Control</u>				
Short	Short	Medium opening (Half open)	Indoor PCB switch 07 bit 1, OFF not Networked, ON Networked				
Outdoor PMV operation							
CN30	CN31	Both PMV's Full OPEN /CLOSED <i>Note: SW08 bit 1 Off</i>					

Please pay careful attention to the labelling of the switches on the interface PCB. Switches are labelled 3 – 2 – 1 from left to right.

Modular Multi Control Set-up example

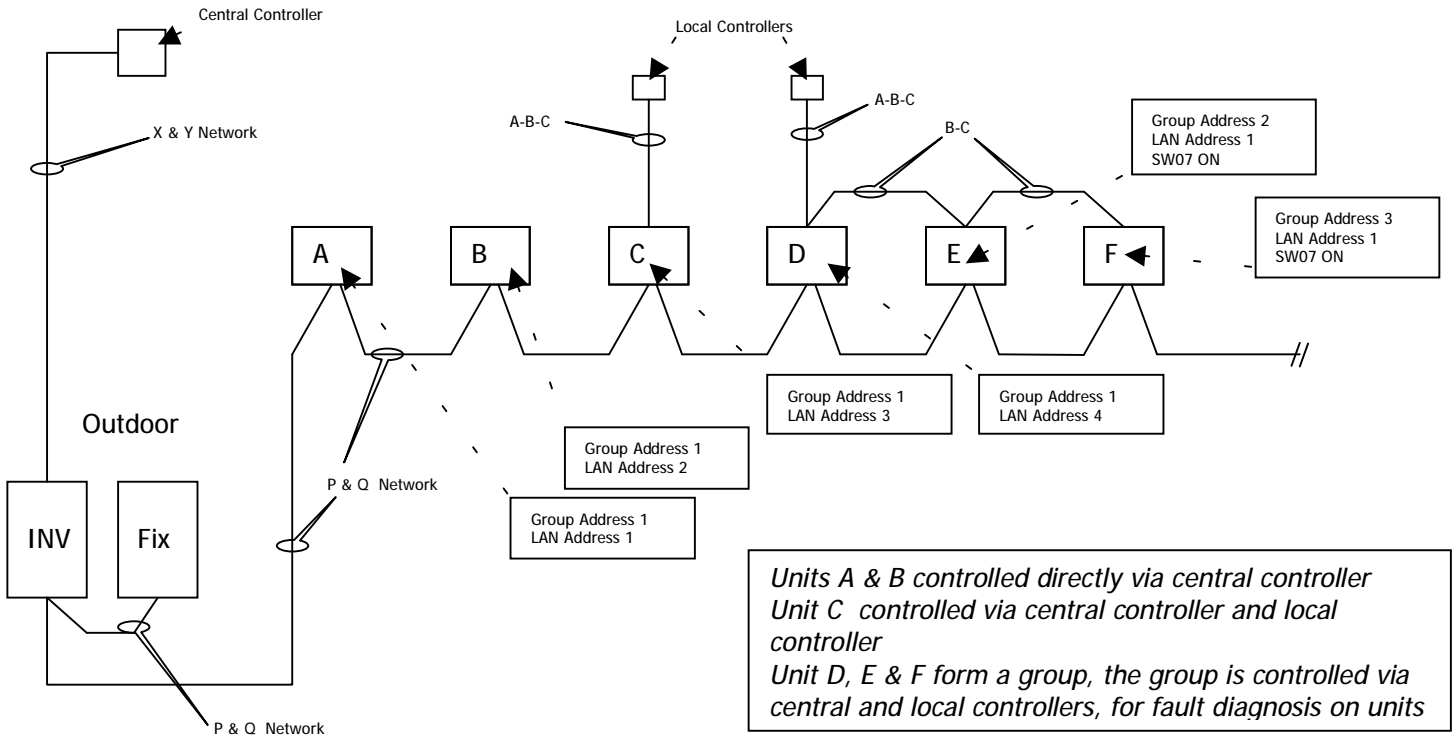

Modular Multi Indoor Units De-Rating Option

The Modular Multi Indoor Units have a de-rating option that can be implemented to closely match actual load requirements. To de-rate any TOSHIBA MMS Indoor Unit adjust Dip Switch SW08 located on the Indoor Unit PCB (MCC-1361-01) in accordance with the chart below. The de-rating options available for the MMS indoor Units are as follows:

Size	Model	Factory Setting (SW08)				De-Rating Option 1				De-Rating Option 2				De-Rating Option 3				De-Rating Option 4								
		1	2	3	4	Size	1	2	3	4	Size	1	2	3	4	Size	1	2	3	4	Size	1	2	3	4	
5HP / 14kW	B140 C/CR140 U140	0	0	X	X	4HP / 11.2kW	0	X	0	0																
4HP / 11.2 kW	B112 C/CR112 U112	0	X	0	0	3.2HP / 8.5kW	0	X	0	X	3HP / 8.5 kW	0	X	X	0											
3HP / 8kW	B080 C/CR080 K/KR080 N080 S/SR080 U080	0	X	X	0	2.5HP / 7kW	0	X	X	X	2HP / 5.6kW	X	0	0	0											
2HP / 5.6kW	B056 C/CR056 K/KR056 N056 S/SR056 TU056 U056	X	0	0	0	1.7HP / 4.8kW	X	0	0	X	1.5HP / 4.2kW	X	0	X	0	1.25HP / 3.5kW	X	0	X	X	1.0HP / 2.8kW	X	X	0	0	
1.5HP / 4.2kW	C/CR042 K/KR042 N042 TU042	X	0	X	0	1.25HP / 3.5Kw	X	0	X	X	1 HP / 2.8Kw	X	X	0	0	0.8HP / 2.24Kw	X	X	0	X						
1 HP / 2.8kW	N028 SB028 Tu028	X	X	0	0	0.8HP / 2.24Kw	X	X	0	X																

NOTE:- No further de-rating options are permitted. KEY:- X = OFF 0 = ON

Manual Operation of Super Multi PMV

Model : 2 and 3 Pipe Super Multi Systems

Reason: When changing a refrigeration component it is essential to ensure that the Pulsed Motor Valves (PMV) in the multi controller(s) are open so that correct recovery and subsequent evacuation is possible.

Each PMV must be opened individually. This is achieved by using the two pins referred to as TP1.

To manually open each PMV in turn:

Step 1: Rotate the display switch to position 0, then link across the two pins TP1 for 2 seconds then remove the link - this opens PMV (A). Rotate the display switch to position 7, display will read PAFO when valve is fully open.

Step 2: Rotate the display switch to position 1, then link across the two pins TP1 for 2 seconds then remove the link - this opens PMV (B). Rotate the display switch to position 8, display will read PbFO when valve is fully open.

Step 3: Rotate the display switch to position 2, then link across the two pins TP1 for 2 seconds then remove the link - this opens PMV (C). Rotate the display switch to position 9, display will read PCFO when valve is fully open.

Step 4: Rotate the display switch to position 3, then link across the two pins TP1 for 2 seconds then remove the link - this opens PMV (D). Rotate the display switch to position 10, display will read PdFO when valve is fully open.

Note: This procedure will open the PMV's for only 2 minutes. To ensure the PMV's stay open through out the evacuation process turn off the power supply to the multi controller once all the valves are fully open.

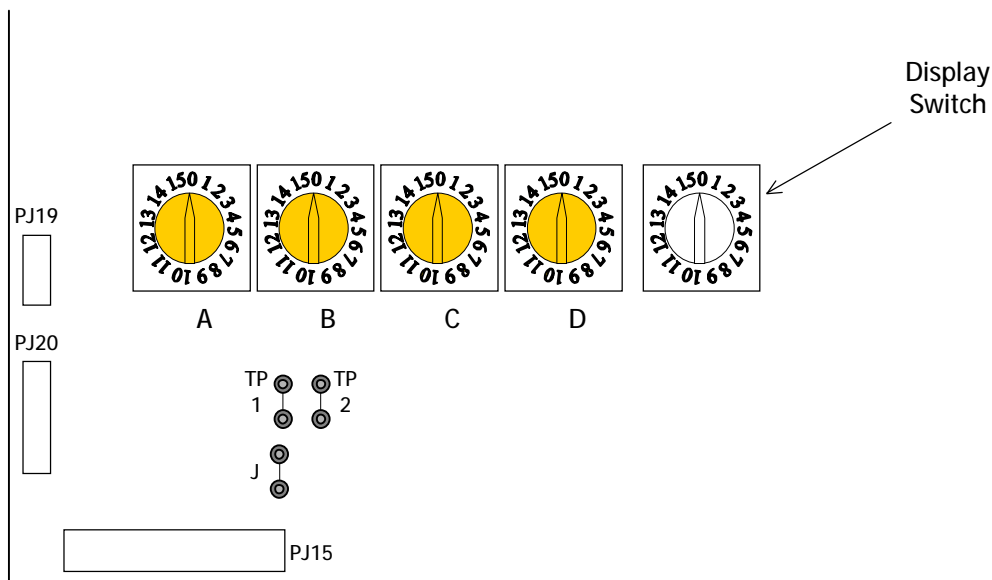

Bottom Left Corner of Multi Controller PCB

TCC-net Controller Guidelines

Digital / Super Digital Inverter SMMS / SHRM VRF



RBC-AMT21-E



RBC-AMT31-E

TCC-net Control – standard wired controller

Features

- 2 wire, screened, non-polarised controller connection
- Infra red control available for cassette models
- Remote temperature sensing available
 - Wired controller
 - Infra red controller
 - Separate room sensor
- Automatic addressing of groups and twins
- Optional control of external fan
- High ceiling compensation
- Time for filter warning is configurable
- Each mode of operation (auto – heat – cool – dry) may have a different temperature set point
- Auto restart is configurable

Cassette PCB

- DC fan motor with feedback circuit
- Red LEDs indicate communication with local controller and PCB activity when illuminated.
- Wired or infra red control (or both)
- Drain pump and float switch

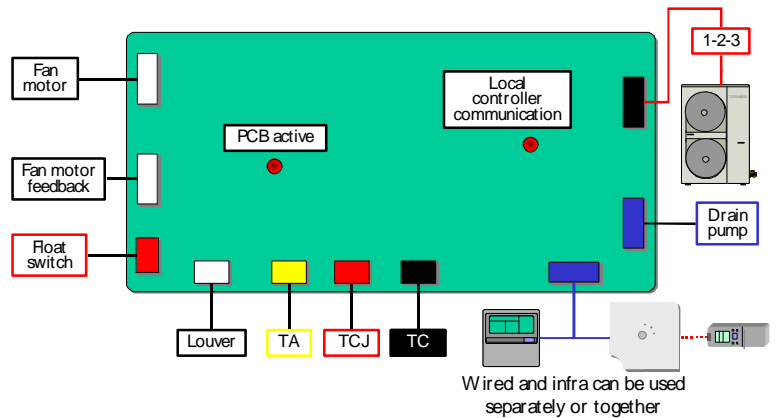

Wired controller

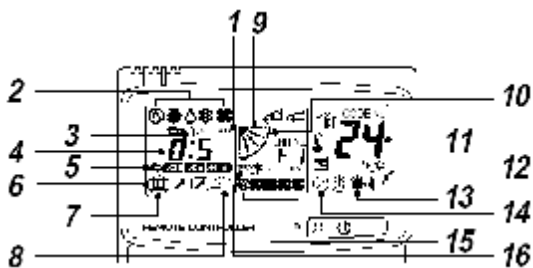

- | | | |
|--|------------------------|--|
| 1. Set data – displayed when setting timer | 6. Filter alert | 12. Displayed when using the remote sensor |
| 2. Operating mode | 7. Not used | 13. Preheat defrost |
| 3. Alarm alert | 8. External fan active | 14. Not used |
| 4. Timer/check code | 9. Louver position | 15. Fan speed |
| 5. Choice of timer mode | 10. Louver swinging | 16. Displayed during test run |
| | 11. Set temperature | |

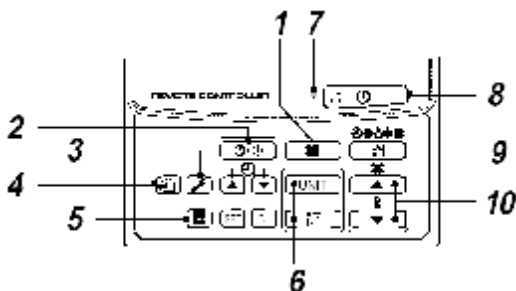

- | | |
|----------------------------|-----------------------------------|
| 1. Fan speed | 6. Unit button and louver control |
| 2. Timer set button | 7. Operation lamp |
| 3. Check button | 8. Operation button |
| 4. Control of external fan | 9. Mode select |
| 5. Filter reset button | 10. Temperature select button |

Group control

- Indoor units may be supplied from any phase
- Up to 8 indoor units per group
 - Automatic addressing
- Any indoor unit may be designated as the “master”
 - Pre-heat indication
 - Filter indication

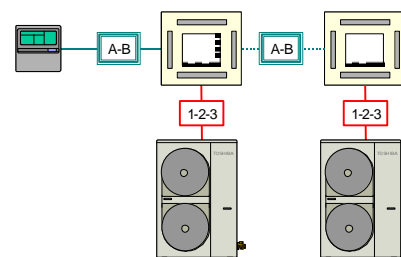

Timer function

Three options are available:

- On after selected time (one cycle)
- Off after selected time (one cycle)
- Off after selected time (re-occurring)

To use, choose one of these options and the time delay before it occurs (minimum period is 0.5 hours). This feature may be locked through configuration item

Louver

- Louver and grille are easily removed for cleaning
- Fixed
 - Louvers can be positioned from the local controller
- AUTO
 - Cooling, horizontal
 - Heating, downward
 - Off, closed
- SWING
 - Activated by pressing the SWING button until the indicator points downward

When grouping, louvers can be set either individually or collectively

Automatic addressing

This takes place when power is applied and can last up to 5 minutes – the address will be selected automatically. If a replacement indoor PCB is fitted, the missing address will be re-applied.

The powered controller screen shows the demarcation lines – and does not indicate that the system is either configuring itself – or is ready to use. If the remote temperature sensor is selected (configuration item 32), the associated symbol will appear when the system is ready for use. If a 9th indoor unit (which can be a protocol converter) is added to a group, the controller will continue to show the demarcation lines.

Adding a system to an existing group (or powering a group up at different times) will require manual configuration (the fault codes will provide guidance).

Identifying an indoor unit

- Stop operation
- Press CHECK and (external) FAN for 4 seconds
 - ALL is displayed
- Indoor fans of the entire group are now energised
- Press UNIT to scroll through group
- Indoor fan of selected indoor unit runs
- Press CHECK to exit.

Test operation

- System must be stopped
- Press CHECK for 4 seconds
 - Controller displays TEST
- Press the ON/OFF button to start operation
- Select MODE of operation
 - HEAT or COOL
- Press the ON/OFF button to stop test
 - System will automatically revert to normal operation after 1 hour
- Press the CHECK button to leave TEST function

Item	Value	Item	Value
00	Room sensor temp	60	TE
01	Controller temp	61	TO
02	TA	62	TD
03	TC	63	TS
04	TCJ	64	Not used
06	Not used	65	THS- heat sink

Data from a wired controller

Press CHECK and CLEAR for 4 seconds - use TEMP buttons to scroll through values shown in table

Fault History

Press CHECK and Set for 4 seconds to view fault history – use TEMP buttons to scroll through past fault histories, 4 per unit in total

TCC-net Control – Central Remote Controller

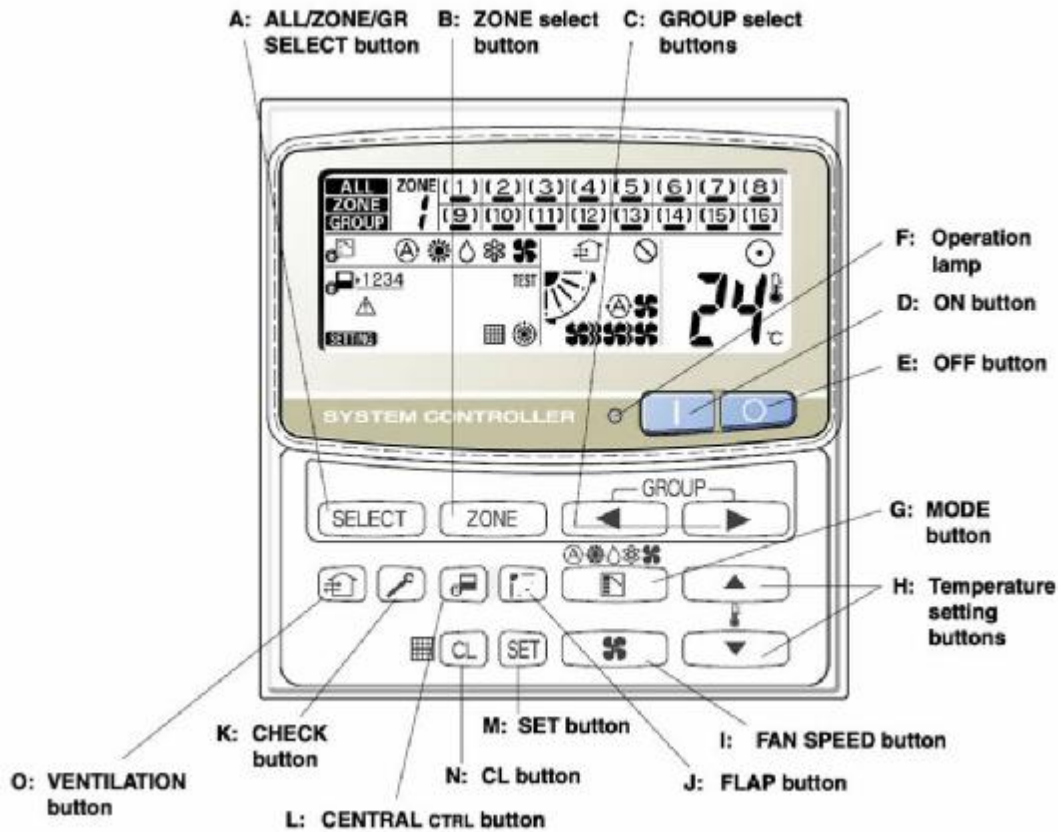

Description

- A: When the unit is in the heating standby mode, the indicator appears.
- B: The currently selected operation mode is displayed.
- C: The currently selected FAN SPEED, Airflow Direction and SWEEP settings are displayed.
- D: This indication appears when the filter needs cleaning.
- E: This indication appears only when an abnormality occurs within a unit.
- F: The currently selected mode (ALL, ZONE or GROUP), ZONE number and GROUP number are displayed.
 - GROUP number display (no figure: no number registered)
 - GROUP state display (1: registered group, 2: currently selected group)
 - Operation state display (—: on, no sign: off, : alarm)
- G: The currently selected central control mode (1, 2, 3 or 4) is displayed.
- H: Lights when any of the air conditioners under the central control is operating; turns off when none of the air conditioners under the central control is operating. Blinks when any conditioner is operating under abnormal conditions and its protection functionality is working.
- I: This indication appears while a test run is underway.
- J: This indication appears when the temperature is set.
- K: When turning on the power switch of the central controller, sign blinks for a few minutes. While blinking, any controls using the central controller are inhibited. This is because the central controller is verifying connected groups.



Central Remote Controller –Dipswitch settings

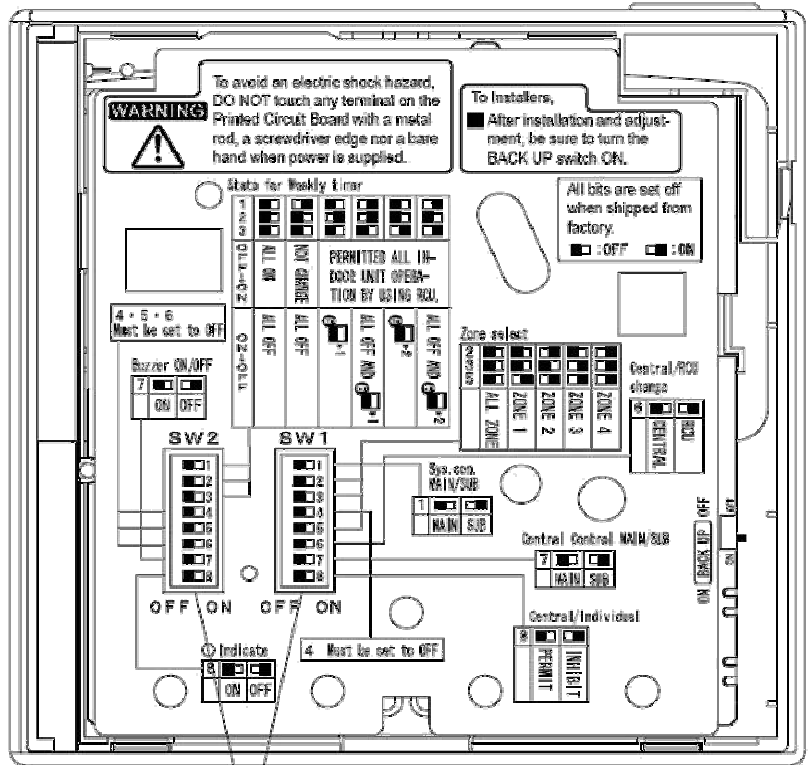

PCB of the control unit

Dip switch

Main/sub selection switch
 OFF: Central controller operates as main controller.
 ON: Central controller operates as sub-controller.

ALL/ZONE mode selection switch
 ALL mode:
 All indoor units can be controlled by central controller.
 ZONE 1, 2, 3, 4 mode:
 Indoor units in one of zone 1, 2, 3, or 4 can be controlled by central controller. All indoor units cannot be set.

	2	3	4	5
ALL mode	OFF	OFF		OFF
ZONE 1 mode	OFF	OFF		ON
ZONE 2 mode	ON	OFF	OFF	ON
ZONE 3 mode	OFF	ON		ON
ZONE 4 mode	ON	ON		ON

Central control/remote control mode selection switch
 OFF: Central control mode.
 Individual setting by remote controller can be inhibited by central controller.
 ON: Remote control mode.
 Setting by central controller is inhibited by other central control equipments.

Central control Main/Sub selection switch
 (OFF: Main, ON: Sub)
 ① When AMY adaptor etc. is used with central controller, set the switch to ON position.
 ② When only one central controller is used, set the switch to OFF position.
 ③ Except ①, when multiple central controllers are used, set only one central controller to OFF position and others to ON position.
 ALL mode central controller to be OFF position. (recommended)

(Central control) button operation switch
 OFF: (Central control) button operation is permitted.
 ON: (Central control) button operation is inhibited.

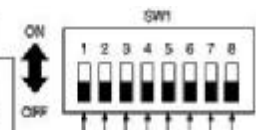

Weekly timer input switches
 Central controller operation can be set when weekly timer activates (ON/OFF).

Central controller operation	Switch No.		
	1	2	5
① All ON	All OFF	OFF	OFF
② No change	All OFF	ON	OFF
③ Individual control of all indoor units to be permitted	All indoor units to be (1) T ⁻¹	OFF	ON
④ Ditto	All OFF and all indoor units to be (2) T ⁻¹	ON	ON
⑤ Ditto	All indoor units to be (3) T ⁻²	OFF	OFF
⑥ Ditto	All OFF and all indoor units to be (4) T ⁻²	ON	OFF

In case of Remote control mode, use ① or ②.
 In case of ZONE 1, 2, 3, 4 mode, ALL, all indoor units means one of ZONE 1, 2, 3, 4.
 *1: (1) (Central control 1) means ON/OFF operation cannot execute by remote controller.
 *2: (2) (Central control 2) means ON/OFF, MODE change, Temp. setting cannot be executed by remote controller.



Auxiliary switch
 Must be set to OFF position.

Beep tone switch
 OFF: Beep tone when each button is pushed.
 ON: No tone when each button is pushed.

Indication switch
 Normally set to OFF position.
 When set to ON position, (i) indication is not displayed on LCD of central controller.

*All switches are OFF position at shipment.

Central Remote Controller –Connections

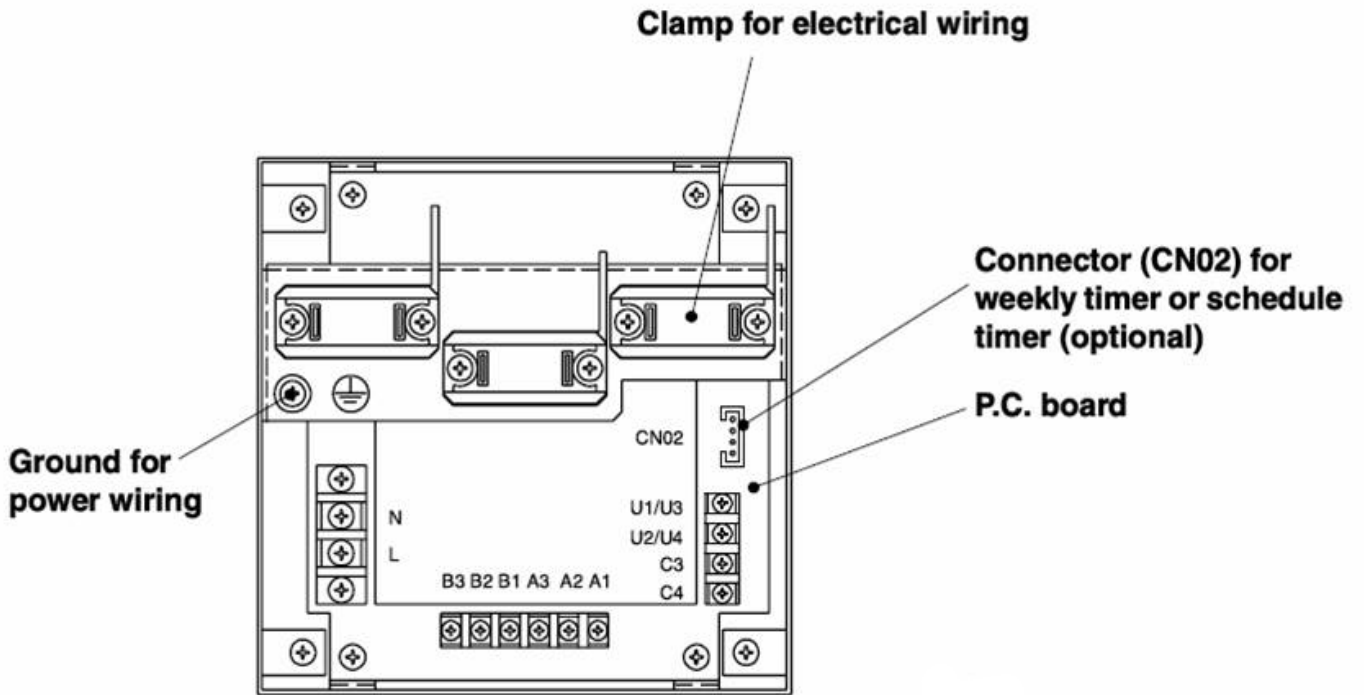

1) Basic wiring

- L: Power supply (240volts 50hz).
- N:
- U1/U3: Indoor unit control wiring (Low voltage).
- U2/U4:
- C3: Auxillary.
- C4: Ground for inter-unit control wiring.
- Ground for power wiring.

2) Terminals for remote monitoring.

- A1: Input for turning ON air conditioning concurrently.
- A2: Input for turning OFF air conditioning concurrently.
- A3: Common input for turning air conditioning ON or OFF.
- B1: On operation statue indicator output
- B2: Alarm indicator output.
- B3: Common indicator output.

Designation	Input/output item	Central controller side		Equipment side		
		Input/output conditions	Terminal name	Demarcation terminals	Circuitry example	Input/output conditions
Digital input/output terminals	Status output	Operate output Alarm output "A" (normally open) contact without voltage Static (relay output) Allowable contact voltage, current: DC 30 V, 0.5 A		CPEV 0.9 to 1.2V		Wiring length: Max. 100 meters
	Control input	All operate input All stop input "A" (normally open) contact with voltage Pulse (photocoupler input) Allowable contact voltage, current: DC 24 V, 10 mA		CPEV 0.9 to 1.2V		Pulse width: 300 ms or more Wiring length: Less than 100 meters

Zone registration using the central controller (RBC-AMT31E)

(RAV models, each individual unit or lead unit of a "Group" must have a TCB-PCNT30TLE interface connected)

In this case, after confirming which indoor unit is connected to the remote controller and that the air conditioner is in the OFF state, you set the central addresses one at a time.

If the system has no remote controller, connect a remote controller to the system temporarily, then follow this procedure.

NOTE

The indoor unit address must already have been set before performing zone registration.

- 1) Press the and buttons at the same time for more than 4 seconds
- 2) Do NOT press button
- 3) Once in this mode, the UNIT No. CODE No. No. of SET DATA and indications will flash on the display as shown in Fig. 13

NOTE

In case of group control "ALL" instead of "UNIT No." will flash on the display. Select the main indoor unit address by pressing the button once.

- 4) Set CODE No. to 03 using the and () buttons.

NOTE

The CODE No. 03 must be selected to perform zone registration using the remote controller.

- 5) Set the Central address, which you want to assign to the indoor unit address using the and () buttons according to the zone registration table.

- 6) Press the button. The CODE No. and the Central address changes from flashing to ON state. If you make a mistake, then press the button and reset the central address.

- 7) Set CODE No. to 12 using the and () buttons.

- 8) Set the Outdoor unit address which you want to assign to the system using the and () buttons. (Each outdoor unit will require a unique address, between 1 and 30)

- 9) Press the button.

- 10) When all address's, Zone and System have been set press the remote controller's display will CLEAR, with flashing, once has cleared the system has been configured.



Fig. 13



For example, in this case
Indoor unit address: 1-8
Central address: 17 (ZONE 2, GROUP 1)

Fig. 14



Zone registration using the central controller (TCB-SC642TLE)

This method is NOT supported by the RAV models

In this case, you set all central addresses by central Controller at once manually.

1) Press the and buttons at the same time for more than 4 seconds.

And CODE No.C1 will flash.

2) After confirming that CODE No.C1 is displayed press the button. Once in this mode, a change takes place as fig 15.

3) Select the zone and group No. which you want to set with and (GROUP) buttons. If already set. Press the button.

4) Set the unit No. (Indoor unit address) with and buttons, according to the zone registration table.

R.C. No.

Indoor unit No.

5) Press the button.

GROUP No. turns ON and UNIT No. (Indoor unit Address) changes from flashing to ON state. Unit No. is registered to selected ZONE No. and GROUP No. If you make a mistake, then press the button and Reselect the ZONE, GROUP and UNIT No.

6) Register the other Unit No. in the same way by following the steps (3) to (5).

7) Finally, complete the registration by pressing the button.

flashes for a few minutes, then OFF.

Automatic zone registration using the central controller (TCB-SC642TLE)

1) Press the and buttons at the same time for more than 4 seconds.

and CODE No. C! will flash.

2) Select CODE. No. C" by pressing and button and press the button.

C2 changes from flashing to ON state and automatic zone Registration will start.

3) Registered GROUP No. will be disappeared all.

4) Central address will be assigned from small indoor unit address to large one in numerical order automatically. Finishing automatic zone registration, changes from Flashing to OFF.

5) If an error occurs, the "CHECK" starts flashing and zone registration finishes at this time. Press the button.

6) Finally, complete automatic zone registration mode by pressing the button.

Flashes for a few minutes, then OFF.

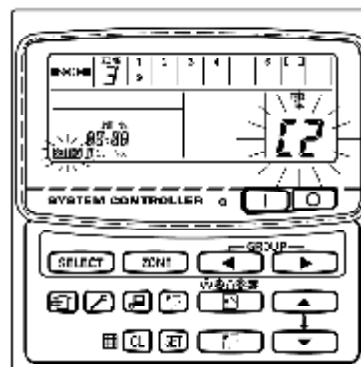

Fig. 15

















For example, in the case at left
Zone 3, group No. 7
Unit No. (indoor unit address) 2-8

Unit No. 2-8 is registered to zone 3-group 7.



Central address duplication error check; C3

* This cannot be used with RAV products. For further details refer to the instructions of the TCC-LINK adaptor.

- 1) Hold down the  and  buttons together for at least 4 seconds. (CODE No, C1 starts flashing)
- 2) Press the  or  () button to select CODE No. C3.
- 3) When the  button is now pressed, CODE No. C3 lights and  flashes. The central address duplication error check now starts.
- 4) The address of all outdoor units is checked in sequence starting with outdoor unit system 1. The check is completed when CODE No. C3 flashes and  goes off.
- 5) If any duplication is discovered among the central addresses, the GROUP No. will flash.
Press the  or  () button to select CODE No. C1, and press the  button.
The central address is cleared by selecting the area where the GROUP No. is flashing and by pressing the  button.
Set the correct central address using the wired remote Controller or the central controller.
- 6) Press the  button to complete the procedure.
 Flashes for several minutes, the initial setting is automatically Established, and the procedure is completed.

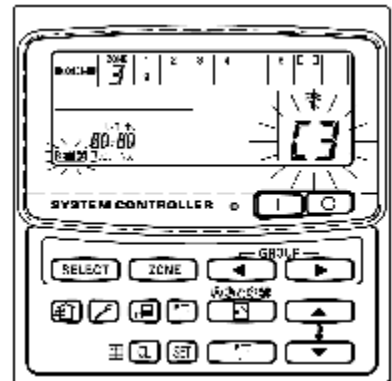

When setting up a central remote controller, which includes more than one outdoor system, each outdoor system needs to have a system address set, factory setting is 1.

Additional systems maybe addressed up to a system number of 28. This is achieved via "Dip switches" SW13 & 14

System address	SW13				SW14			
	1	2	3	4	1	2	3	4
1				X	X	X	X	X
2				X	O	X	X	X
3				X	X	O	X	X
4				X	O	O	X	X
5				X	X	X	O	X
6				X	O	X	O	X
7				X	X	O	O	X
8				X	O	O	O	X
9				X	X	X	X	O
10				X	O	X	X	O
11				X	X	O	X	O
12				X	O	O	X	O
13				X	X	X	O	O
14				X	O	X	O	O
15				X	X	O	O	O
16				X	O	O	O	O
17				O	X	X	X	X
18				O	O	X	X	X
19				O	X	O	X	X
20				O	O	O	X	X
21				O	X	X	O	X
22				O	O	X	O	X
23				O	X	O	O	X
24				O	O	O	O	X
25				O	X	X	X	O
26				O	O	X	X	O
27				O	X	O	X	O
28				O	O	O	X	O

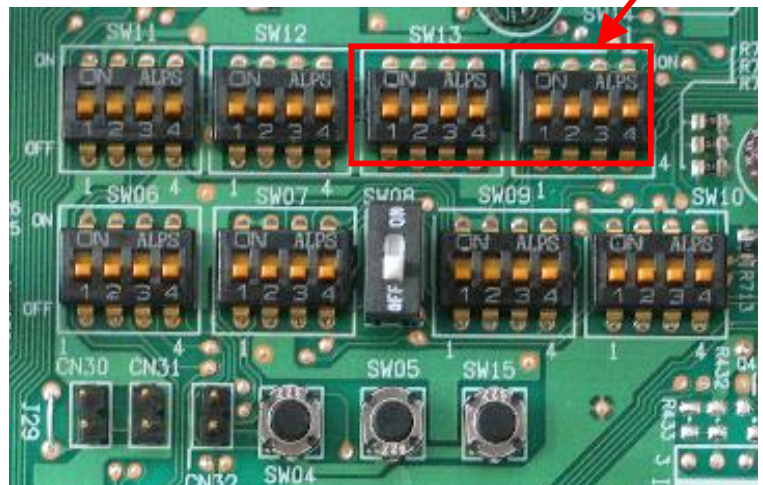

Central Remote Controller – wiring examples

Basic wiring diagram

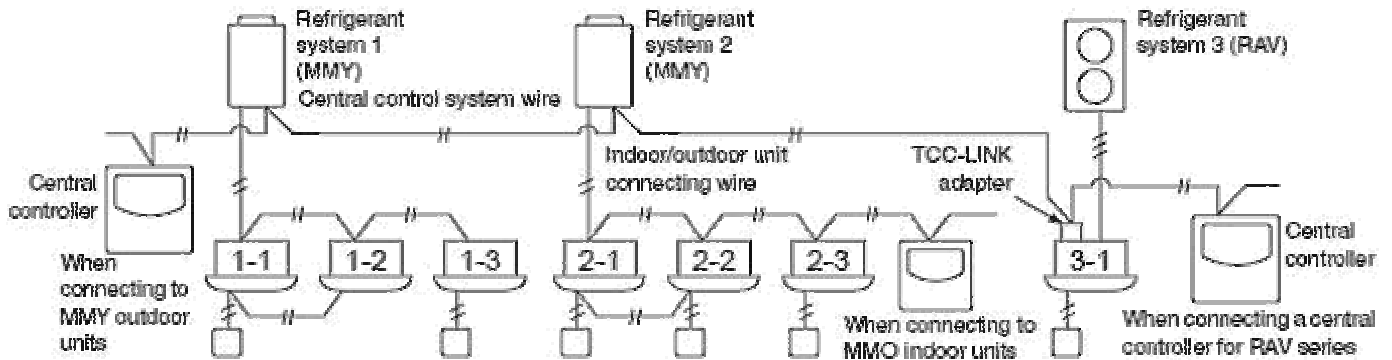

MMO: Super Modular Multi Indoor Unit model name.
(MMU, MMD, MMC, MML, MMK and MMF)

When connecting a central controller for RAV series indoor unit (except KRT), add the TCC-LINK adapter on indoor unit.

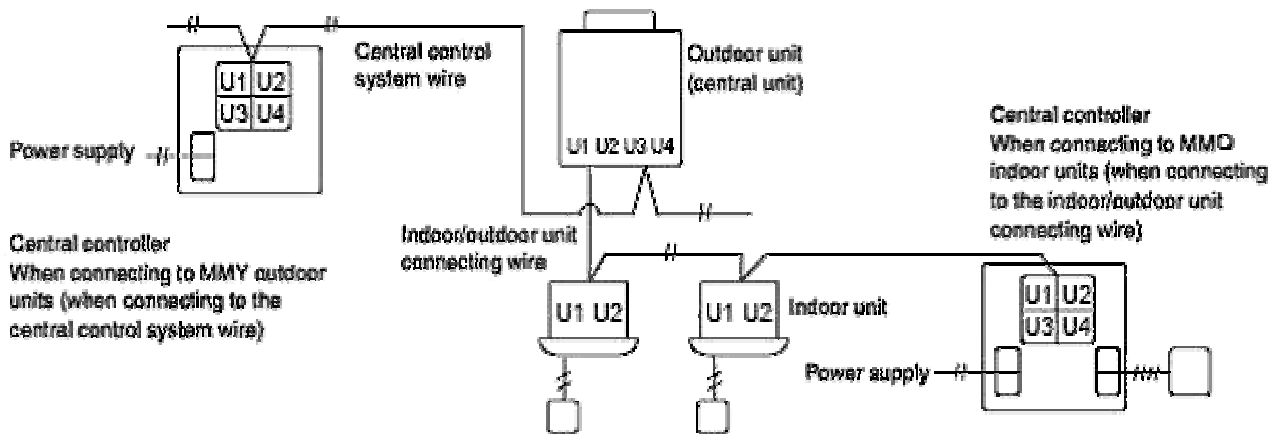
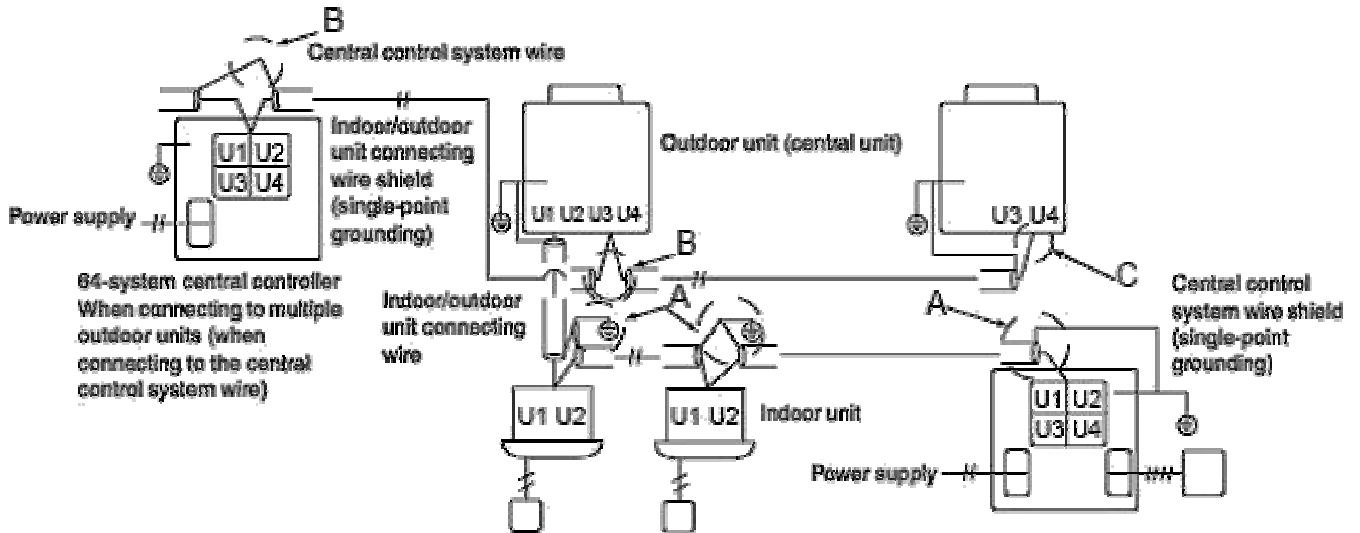

Option 3

Central Controller Connected To SMMS/SHRM Indoor/Outdoor

Note: The SMMS / SHRM2 System MUST be commissioned prior to connection Of the Central Controller

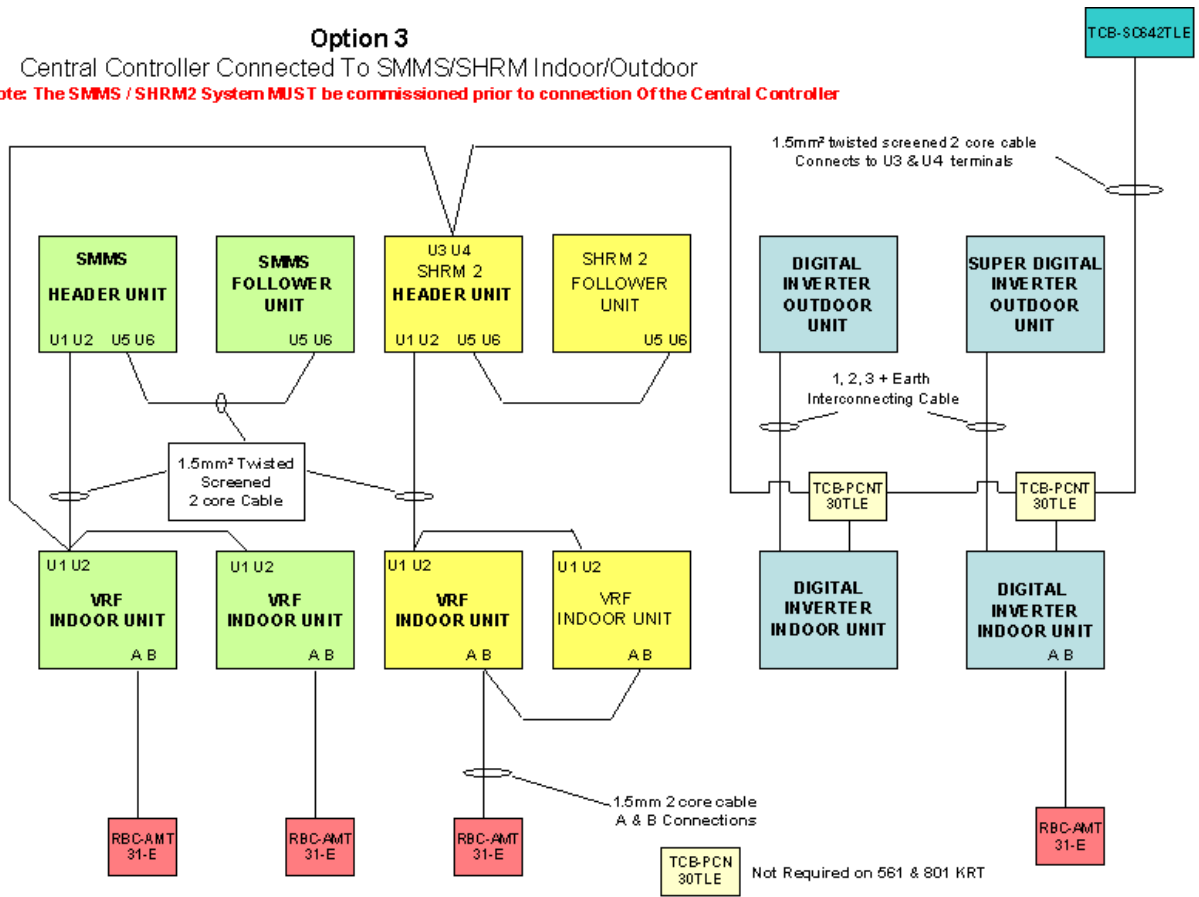

Option 4

AI Central Controller Connected To SMMS/SHRM/RAV/RAV-SM

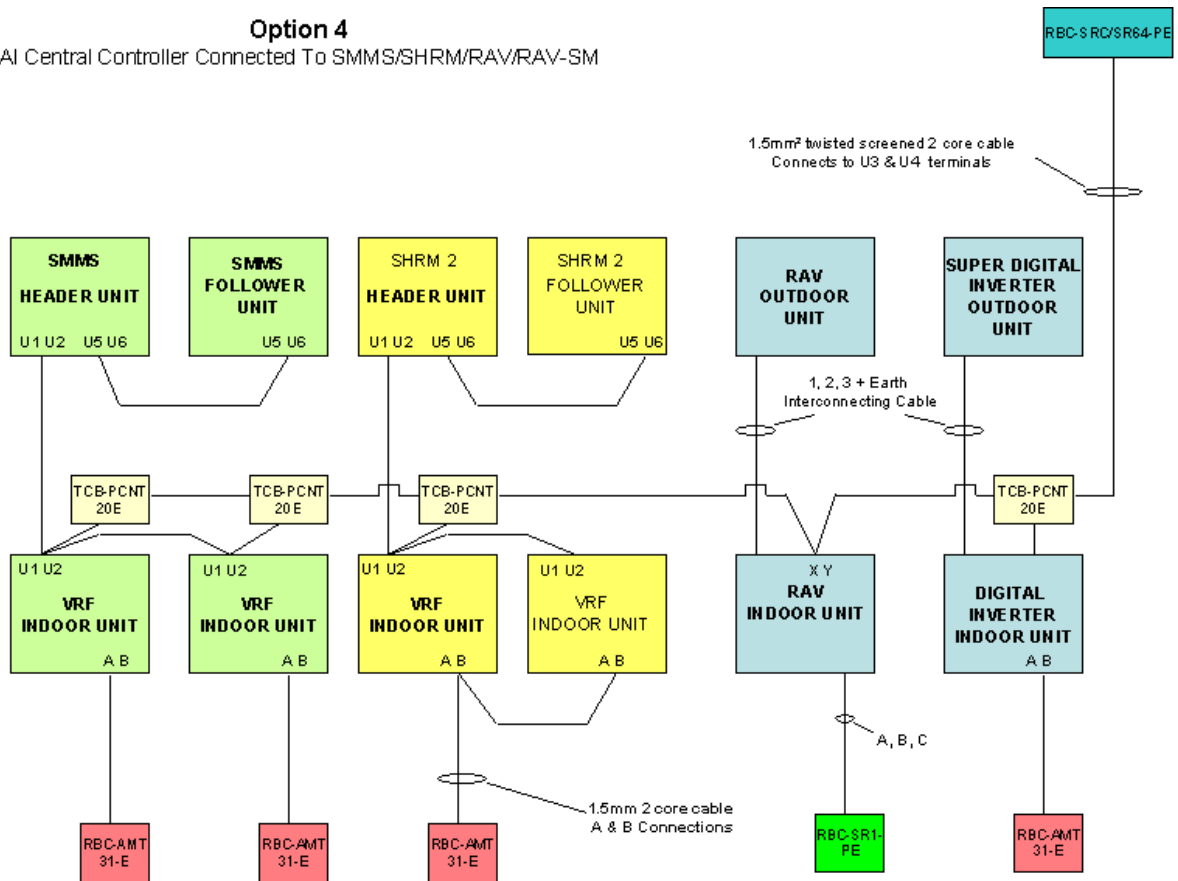

Configuration menu

A number of items are configurable by the wired controller – if an indoor unit without a wired controller requires configuration, it may be temporarily connected for the procedure to be undertaken. In order to access the menu,

Press + SET + CL for 4 seconds

Item	Description		Value	Default
01	Filter alarm time	Filter sign displayed after selected time has elapsed – or by external pressure switch (CN70)	0000: Inactive 0001: 150 H 0002: 250 H 0003: 500 H 0004: 1000 H 0005: External switch	0004
02	Dirty environment	Allows filter alarm time to be halved if used in a dirty environment	0000: Standard 0001: Dirty	0000
03	Network address	When under network control.	0099: Unset 0001 to 0064 available	0099
04	Priority Setting for Remote Controller	0 = Normal 1 = Priority (This remote has priority of mode setting)	0000 = Standard 0001 = Priority	0000
06	Stratification control	Increases effective return air temperature setting in heating mode (0 to 10 K)	0000 to 0010	0002: +2°C (Floor type 000: 0°C)
0C	Preheat	Preheat indication on display	0000 = available 0001 = unavailable	0000
0d	Auto mode	Enable or disable Auto mode	0000 = available 0001 = unavailable	0000 except SMMS
0E	SHRM only	Used when multiple indoor units are served via a single FS box	0000 = normal 0001 = multiple units	0000
0F	Heat Mode	Enable or disable Heat Mode	0000 = available 0001 = unavailable	0000
10	Indoor unit model	Must be set when replacing indoor printed circuit board	0000: 1 way cassette (s models) 0001: 4 way cassette 0002: 2 way cassette 0003: 1 way cassette (y models) 0004: duct (standard) 0005: slim duct 0006: duct (high static) 0007: ceiling 0008: hi wall 0010: console 0011: concealed floor 0014: 4 way cassette (600 x 600) 0013: tall cabinet	
11	Indoor unit capacity	0000 will generate a (L09) fault	0001 = 0.8hp 0003 = 1hp 0005 = 1.25hp 0007 = 1.7hp 0009 = 2hp (056*) 0011 = 2.5hp 0012 = 3hp (080*) 0013 = 3.2hp 0015 = 4hp (110*) 0017 = 5hp (140*) 0018 = 6hp 0021 = 8hp 0023 = 10hp	
12	Outdoor unit #	Each indoor unit is automatically addressed – this value may be set manually but it must be done via the wired controller – on an individual basis. Settings are 0001 to 0030	0001: outdoor unit 1 0002: outdoor unit 2	0099
13	System number	Indoor units connected to a common outdoor unit (e.g. twinned indoor units) will have the same system number - settings are 0001 to 0064. Automatically allocated – but may be manually overridden.	0001: indoor unit 1 0002: indoor unit 2	0099
14	Group master/slave	Allows selection of master indoor unit within group. Automatically allocated – but may be manually overridden.	0000: single indoor unit 0001: group master 0002: group slave	0099
15	Temperature Sensor	Compensation for missing temperature sensor (split systems ONLY) – other settings produce F03 fault code	0022	0022
16	Indoor Fan	Indoor fan speed selection. Binary addition.	0015 = all speeds available 1 – auto; 2 = low; 4 = medium; 8 = high	0015 except high static (008)
17	Set point shift	Cooling temperature set point shift. (shifted by 1 to 10 k)	0000 = no shift 0001 = 1 k shift 0010 = 10 k shift	0000
19	Louver functions	None, swing only, swing and auto (where applicable)	0000: disabled 0001: swing only 0004: all options	

Item	Description		Value	Default
1b	Compressor on time	Compressor minimum on time 0 = 5 minutes 1 = 4 minutes	0000: 0 – 5 min. 0001: 1 - 4 min.	0000
1C	Thermo Shift	Thermal shift of Discharge Air in Cooling Mode	-005 = 5°C -004 = 4°C 0000 = 0°C 0010 = 10°C	
1E	Dead band - auto	Changeover sensitivity in automatic mode. 1 to 10 k adjustable	0000: 0 K 0010: 10 K	0003
1F	Max. Setting	Cooling mode maximum temperature setting (18 – 29)	0018 = 18° C 0020 = 20° C 0029 = 29° C	29° C
20	Min. Setting	Cooling mode minimum temperature setting (18 – 29)	0018 = 18° C 0020 = 20° C 0029 = 29° C	18° C
21	Max. Setting	Heating mode maximum temperature setting (18 – 29)	0018 = 18° C 0020 = 20° C 0029 = 29° C	29° C
22	Min. Setting	Heating mode minimum temperature setting (18 – 29)	0018 = 18° C 0020 = 20° C 0029 = 29° C	18° C
23	Max. Setting	Dry mode maximum temperature setting (18 – 29)	0018 = 18° C 0020 = 20° C 0029 = 29° C	29° C
24	Min. Setting	Dry mode minimum temperature setting (18 – 29)	0018 = 18° C 0020 = 20° C 0029 = 29° C	18° C
25	Max. Setting	Auto mode maximum temperature setting (18 – 29)	0018 = 18° C 0020 = 20° C 0029 = 29° C	29° C
26	Min. Setting	Auto mode minimum temperature setting (18 – 29)	0018 = 18° C 0020 = 20° C 0029 = 29° C	18° C
28	Auto restart	Enable or disable	0000: disabled 0001: enabled	0000
29	Humidifier condition	Operating condition of humidifier	0000: Usual 0001: Condition ignored	0000
2A	CN70	Selection of optional error input (CN70)	0000: Filter input 0001: Alarm input 0002: None	0002
2d	Modes available	Binary addition of modes available. Split systems 0000, will fault the system	0015 = all modes 1 = fan; 2 = cool; 4 = dry; 8 = heat	0015
2E	External On / Off control	Making or breaking terminals 1 and 2 of CN61 (indoor pcb) External switching option, remove jumper 01 master indoor pcb allows continuous contact switch- link 01 in place; pulse switch required	0000 = group starts when made stops when open 0001 = enable when made, disable when open	0000
30	Automatic grille	Automatic elevating grille control	0000: Unavailable 0001: Available	0000
31	External fan control	Through remote controller and CN32 indoor pcb	0000 = disable 0001 = enabled	0000
32	Sensor location	Return air/room sensor OR in local controller	0000: return air sensor 0001: remote sensor	0000
33	Unit of temperature	Celsius or Fahrenheit	000 = Celsius 0001 = Fahrenheit	0000
40	Drain pump	Drain pump control	0000: None 0001: Pump ON 0002: None 0003: Pump OFF	0003
45	Anti smudge	4 way cassette – anti smudge effect via louver position	0000 = enabled 0001 = disabled	0000
5d	Airflow correction	Used with high ceilings or applications with high sensible loads	0000: standard 0003: high (duct) 0004: low (except duct) 0006:low (duct); ultra high others	0000
60	Timer lock	Locks timer in wired local controller – maintaining last setting	0000: unlocked 0001: locked	0000
62	Anti smudge	4 way cassette – ant smudge via fan speed (Coanda effect)		0001
69	Louver	Louver restriction when cooling	0000 = restricted to horizontal positions 0001 = full range of movement	0000
8b	Heating Correction	Heating output reduction split systems only	0000: None 0001: Correction	0000
8C	Forced Defrost	Run group in HEAT mode after setting defrost is conducted automatically. Value is reset automatically back to 0000	0000 = disabled 0001 = enabled	0000
91	Certification settings (reduced)		0000 = standard 0001 = test 0002 = low capacity	0000
AO	Fan & Pump	Fan and pump operation during oil retrieval mode (VRF cassettes ONLY)	0000 = fan off, pump on 0003 = fan on, pump on	0003

- The indoor units to be configured will be chosen by pressing the UNIT button.
 - The indoor unit being configured runs its fan and swings its louvers (if possible).
 - Use SET TEMPERATURE up/down buttons to scroll through the configurable items Use TIMER up/down buttons to choose the configuration value Use
 - SET to confirm configuration value Use CL to undo an incorrect setting (provided that configurable item has not been changed)Use CHECK to return to normal operation

Extras TCCJ Control options

Item	Description	Model Name	Details
1	Wired remote controller	RBC-AMT21E	Hard wired remote controller (superseded)
2	Wired remote controller	RBC-AMT31E	Hard wired remote controller with extended timer functions (replaces AMT21E)
3	Weekly timer	RBC-EX21E	7 day timer with day omit, suitable for connection to items 1, 2 & 10
4	External timer interface lead	RBC-SMT1	Interface lead to connect an external timer, (supplied separately) with items 1,2 & 10
5	Wired remote controller	RBC-AS21E	Simplified hard wired remote controller
6	Infra red remote kit	TCB-AX22CE	Wireless remote unit kit suitable on Ceiling suspended units
7	Infra red remote kit	TCB-AX21E	Wireless remote unit kit suitable on Ducted Units
8	Infra red remote kit	TCB-AX21U(W)E	Wireless remote unit kit suitable on 4 way Cassette units
9	Remote Sensor	TCB-TC21LE	Remote temperature sensor
10	Central remote controller	TCB-SC642TLE	Central controller suitable for controlling 64 units
11	Fault indicator module	RBC-FDP2-PE	Fault indication module connects to indoor control circuit
12	Twin kit	RBCTWP30E	Twin kit to enable twinning on 1100 / 1101 outdoor units
13	Twin kit	RBCTWP50E	Twin kit to enable twinning on 1400 / 1401 outdoor units
14	External fan control	RBC-SMF1	Interface to enable control of an external fan
15	Drain pump kit	TCB-DP10CE	Drain pump kit designed for the XT unit, (ceiling mount only)
16	Drain pump kit	TCB-DP22CE	Drain pump kit designed for the ceiling suspended unit
17	Network / Protocol adaptor	TCB-PCNT20E	Adaptor kit to enable integration with AI network controls
18	1:1 interface	TCB-PCNT30LE	Adaptor kit to enable 1:1 systems to integrate with VRF systems
19	Remote On / Off	TCB-IFCB-4E	Enables remote On / Off (SMMS / SHRM)
20	Error output interface	TCB-PCIN2E	Error output interface (SMMS / SHRM)
21	Peak Power	TCB-PCDM2E	Power peak control interface (SMMS / SHRM)
22	External On / Off	TCB-PCM02E	External interface to enable remote On / Off
23	Flow selector box electrical extension	RBC-CBK15FE	10 m extension cables for flow selector boxes

PCB plugs

External fan control	CN32	12VDC output
IP1	CN60	1 common (12 VDC) 2 defrost 3 compressor on 4 cooling mode 5 heating mode 6 indoor fan on
HA circuit	CN70	
Filter input	CN70	1 filter switch 2 0 VDC
Check function of indoor unit no communication Takes place – just indoor functions	CN71	1 check function 2 0 VDC
Display mode enables indoor unit and controller to communicate when powered	CN72	1 check function 2 0 VDC
EXCT demand forces compressor off	CN73	1 check function 2 0VDC
Leak detector etc – L30 code generated	CN80	1 common (12 VDC) 2 common (12 VDC) 3 input

Integration with AI network control

TCC-net models use a different language to AI – however a TCC-net group can be linked to an AI network, by the use of a protocol converter. This device is not standard and should be fitted on site – a group requires only one protocol converter to communicate with a network.

An LED flashes to indicate communication with the network.

The Protocol converter provides terminals X-Y for the network connection – it also has the 7-way DIP switch used to give a network address – the method is identical to that used for AI indoor units.

The network address may also be set by a wired controller – from the configuration menu.

The protocol converter is counted as an indoor unit – only 7 indoor units may therefore be group controlled in this way.

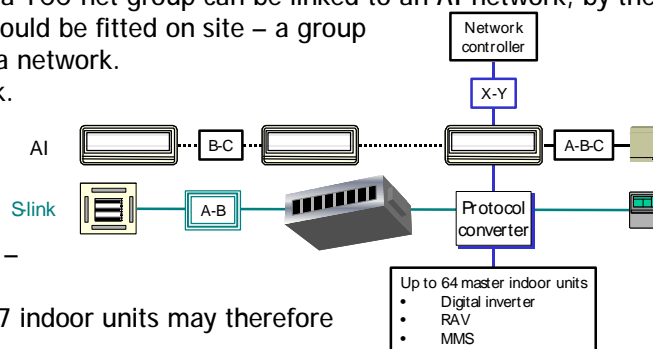

Second controller

- Options available
 - 2 x wired controllers
 - 1 wired + 1 infra red controller
- Full group control from either
- Connection may be anywhere within group
- Changes updated

The sub-controller must be set – this can be done from either controller. The choice of sub-controller makes little difference unless it is required to act as the temperature sensor

Temperature sensing

Both infrared and wired controllers are able to supply a temperature value to the indoor unit. This may be more representative than the standard, return air sensor but is not available from sub controllers of either type. To set the room sensor:

- Infrared controller – press MAIN SENSOR
- Wired controller – selected from configuration menu

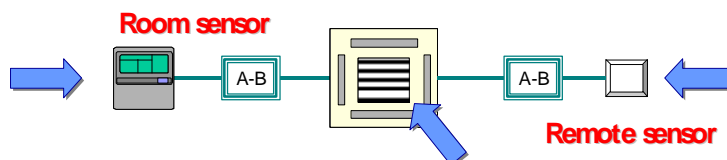

Should the infrared controller lose contact with the indoor unit, return air temperature control will automatically resume. A further option for remote sensing is available – the remote sensor. This is connected to terminals A-B whether or not a wired controller is used. The indoor unit must, in this case, be set to use the standard, return air sensor – this sensor automatically takes over in this case.

This value will be used to provide control to all indoor units within the group.

Assorted wiring diagrams for auxiliary devices.

RBC IT2-PE

Compatible with RAV - 0,1,2,3,4 & 5 series

External switch can be, any electrical 240-volt AC device, i.e. Time switch, passive switch, key switch etc. For heat pump application refer to fig. 1, for cooling only application refer to fig 2

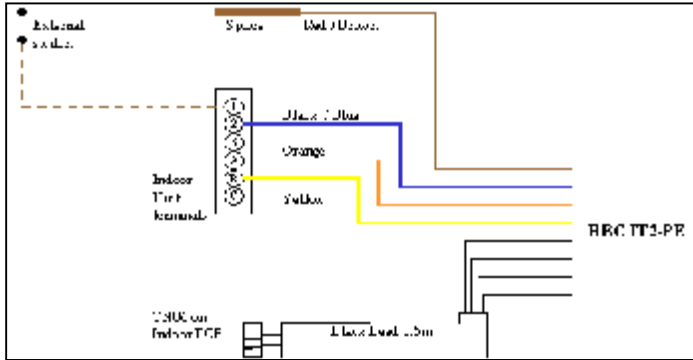

Fig 1

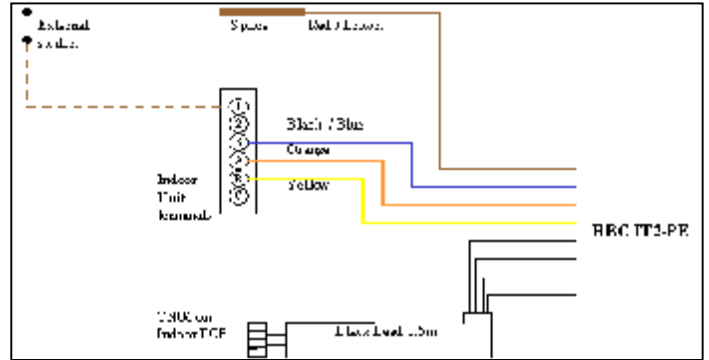

Fig 2

RBC IT2-PE

Compatible with RAV - 0,1,2,3,4 & 5 series

When used as an auto restart device, for heat pump application refer to fig 3, for cooling only application refer to fig 4

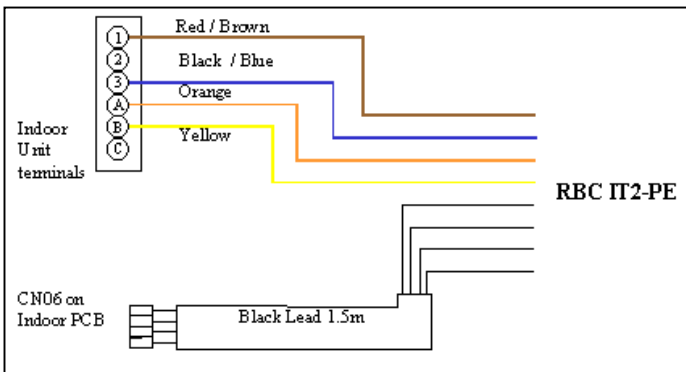

Fig 3

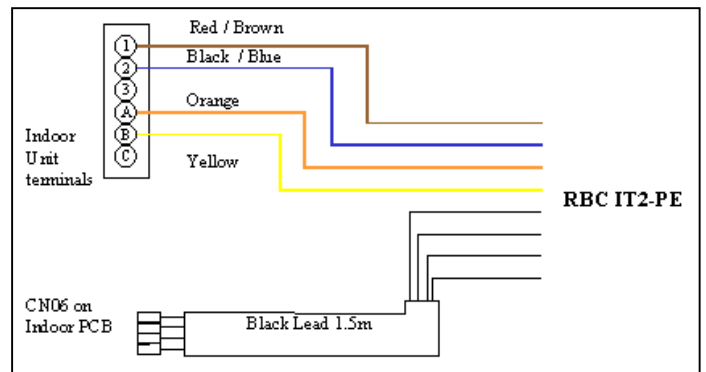

Fig 4

RBC IT3-PE

Compatible with RAS - Daiseikai

External switch can be, any electrical 240-volt AC device, i.e. Time switch, passive switch, key switch etc. Refer to fig. 5 and fig 6

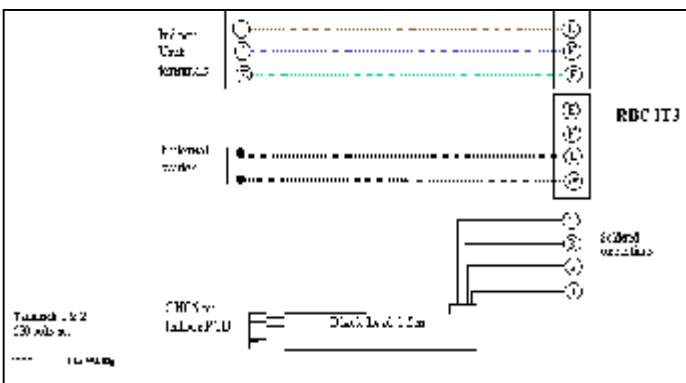

Fig 5

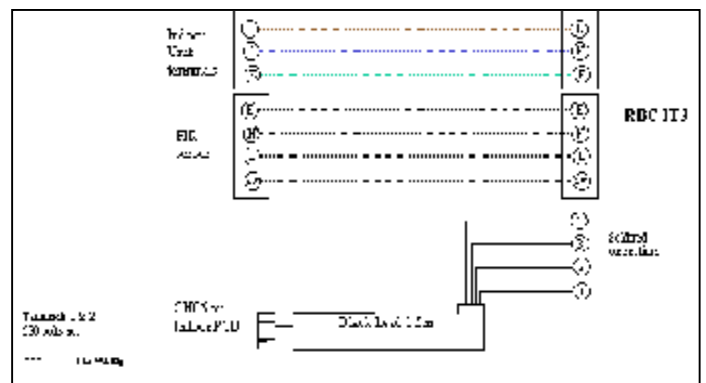

Fig 6

RBC IT4-PE

Compatible with RAV SM (Digital / Super digital inverter)

External switch can be, any electrical 240-volt AC device, i.e. Time switch, passive switch, key switch etc. Refer to fig. 7 and fig 8.

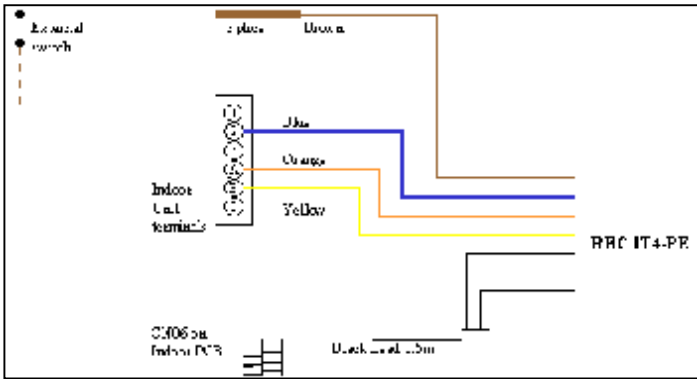

Fig 7

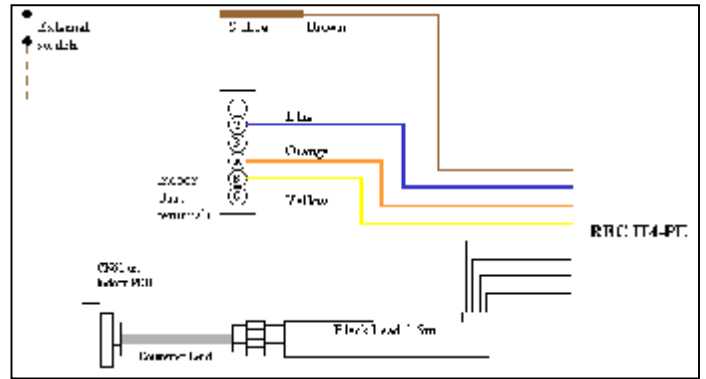

Fig 8

Indicator panel IP1

Compatible with RAV – 0,1,2 & 3 series

R22 HEAT PUMP units, *not suitable for cooling only* Equipment. Wiring configuration refer to fig. 9

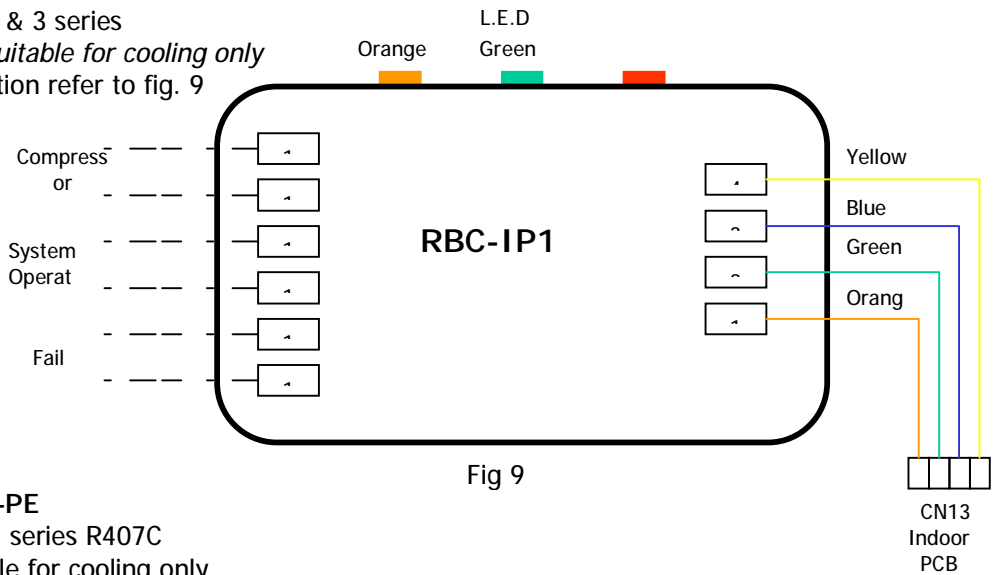

Fig 9

Indicator panel RBC-IM1-PE

Compatible with RAV – 4 & 5 series R407C

HEAT PUMP units, *not suitable for cooling only* Equipment, Wiring configuration refer to fig. 10

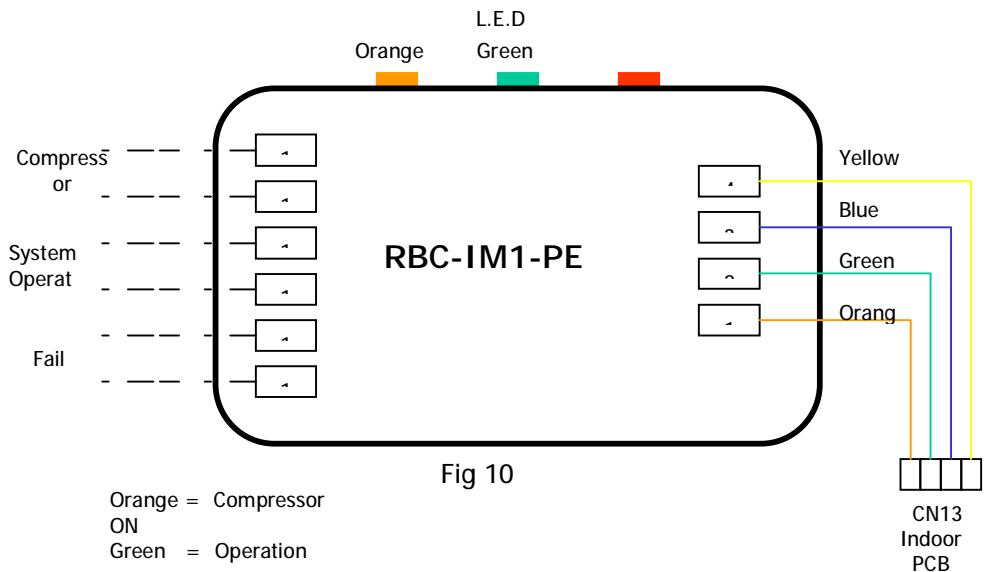

Fig 10

RBC SMT1 Digital Inverter Timer Interface

Compatible with RAV SM (Digital / Super digital inverter) via RBC-AMT21/31E Remote Controller

External Switch, Volt Free Contact, i.e. Time switch, passive switch, key switch etc.
Refer to fig. 11.



Fig 11

RBC SMF1 Digital Inverter Fan Interface

Compatible with RAV SM
(Digital / Super digital inverter)

The accessory will allow an external ventilation fan
To be controlled via the indoor unit
Refer to fig. 12.

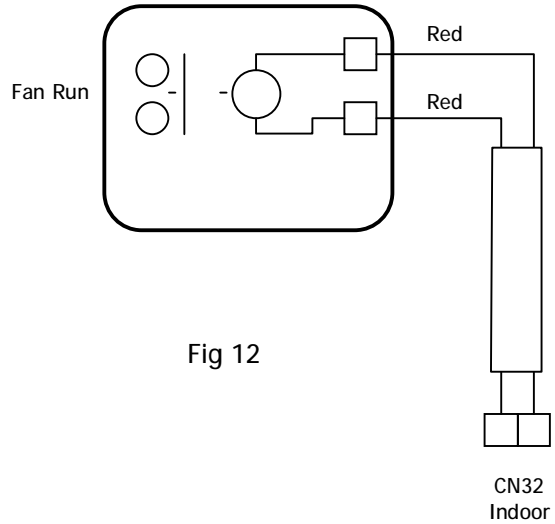

Fig 12

TCB-IFCB-4E Remote location ON/OFF control Compatible with RAV SM (Digital / Super digital inverter)

The accessory will allow for external ON/OFF, with
Operation and Alarm
indication Refer to fig. 13.

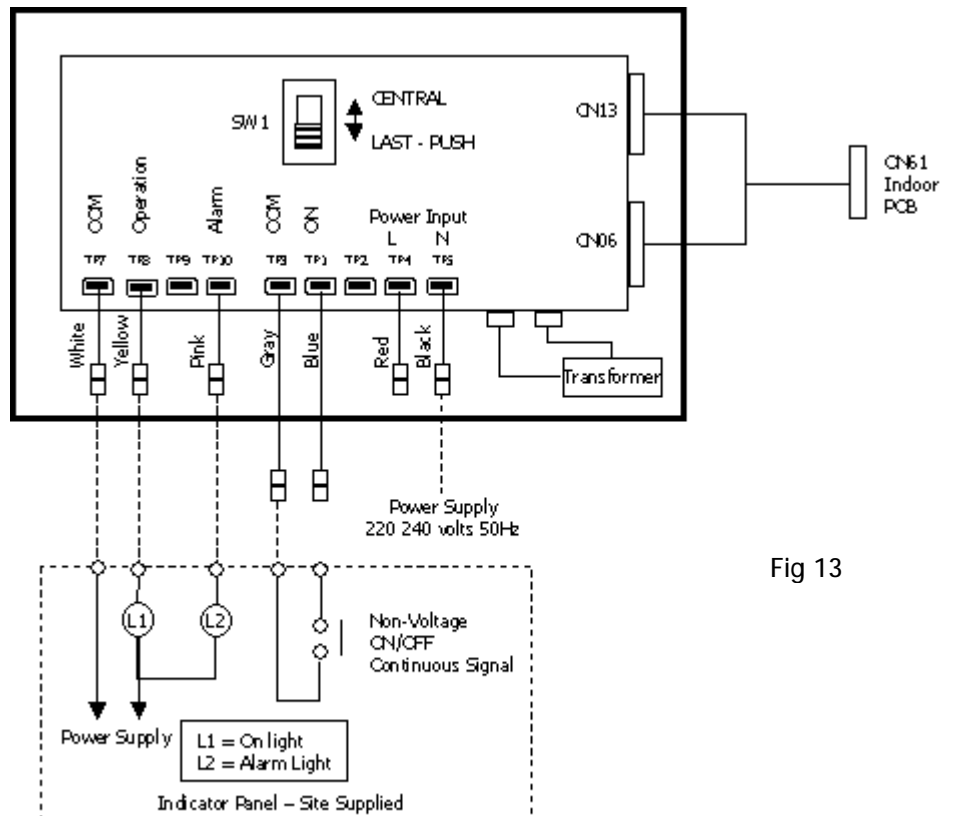

Fig 13

Common Sensor Characteristics

There are five commonly used sensors used in the RAS and RAV systems.

- Ta = Return Air Sensor; indoor unit
- Tic = Coil Sensor; indoor unit
- TL = Liquid Pipe Sensor (fan speed); outdoor unit
- TE = Heat Exchange Sensor (defrost); outdoor unit
- Td = Discharge Pipe Sensor; outdoor unit

The Ta, Tc, TL and TE sensors all share the same resistance vs. temperature characteristic. They differ however in electrical connections and sensing head style, therefore it is important to quote the full model number when ordering any replacement sensors.

The Td sensor has a different resistance characteristic because its sensing range is that much higher than the others.

Sensor	-10	-5	0	5	10	15	20	25	30	35	40	45	50	55	60	100	°C
Ta, Tc, TL, TE	60.3	45.3	34.5	26.4	20.5	16	12.5	10	8	6.5	5.3	4.3	3.6	2.9	2.4	-	KΩ
Td	-	-	-	-	103	80.5	63	50	-	-	-	-	17.9	-	-	3.4	kΩ

TA, TC, TL & TE Sensor data

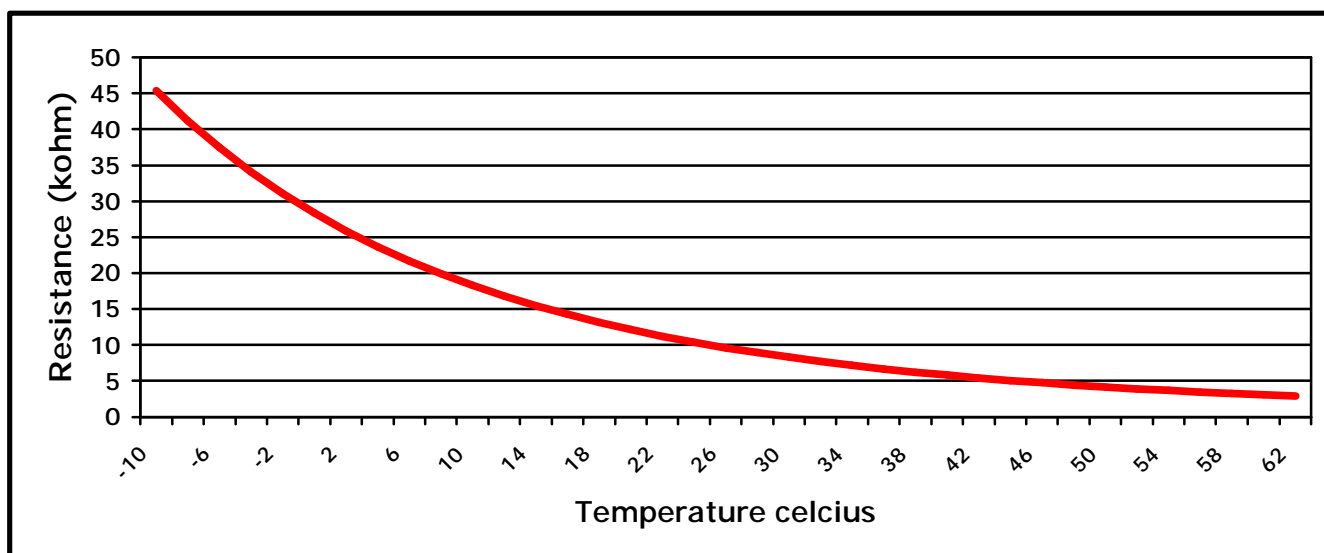

TD Sensor data

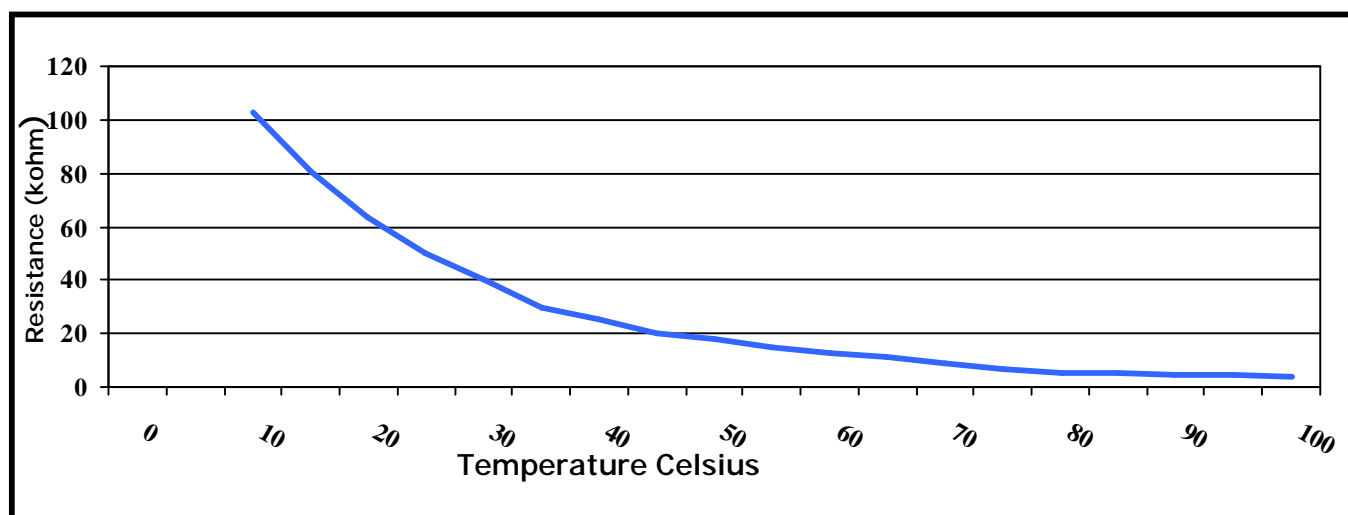

New Harmonised Electrical Wiring Colours.

Amendment No. 2 to BS 7671: 2001 (IEE Wiring Regulations)

Affective 31st March 2004, new electrical installations may use the new harmonised cable colours or the pre-existing colours but not both.

Works commencing after 31st March 2006 will be required to comply with the harmonised cable colours only, old coloured cables must not be used.

Existing
Cannot be used after 31 March 2006

New (harmonised)
May be used from 31 March 2004

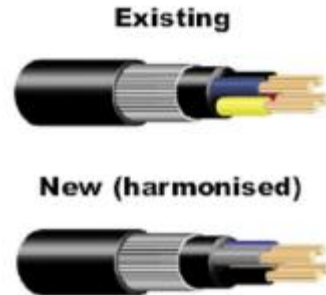

Alterations to existing single-phase installations.

Alterations or additions to a single-phase installation do not require marking at the interface between old and new cabling. Providing that they are correctly coloured.

A warning notice must be attached at the distribution board or consumer unit.

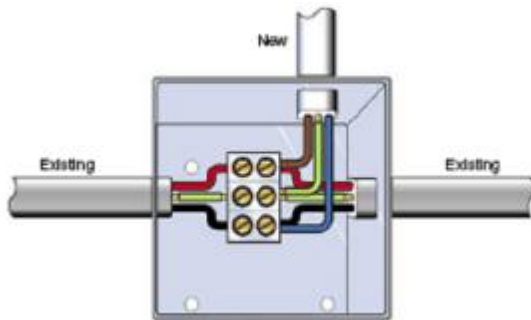

Alterations to existing three-phase installations.

Alterations or additions to a three-phase installation, it is recommended that old and new cables are marked at the interface L1, L2, and L3 for the phases and N for the neutral. The marking should be made to both the new and the old cables.

A warning notice must be attached at the distribution board.

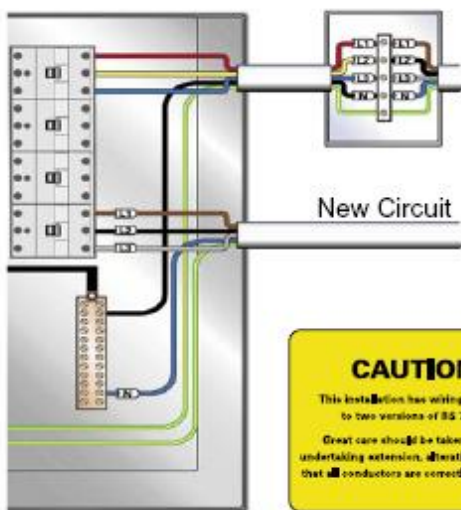

Existing		Harmonised
Red	L1	Brown
Yellow	L2	Black
Blue	L3	Grey
Black	N	Blue

Red	L1	Brown
Yellow	L2	Brown
Blue	L3	Brown
Black	N	Blue

In addition to the New Harmonised Electrical Wiring Colours.

From the 1st January 2005. New rules for Electrical Safety in Homes (Electrical Safety Part P) came into force.

The rules in brief are;

From the 1st January 2005. People carrying out electrical work in homes and gardens in England and Wales will have to follow the new rules in the Building Regulations.

Persons carrying out electrical works within a domestic environment must be registered with a "competent person scheme".

Full details can be obtained from; www.odpm.gov.uk/explanatory-booklet alternatively call 0870 1226 236

For details of the "Approved Document P" visit www.odpm.gov.uk/approved-documents alternately a copy can be purchased from the Stationary Office, for £15.00. To order call 0870 600 5522

Technical Support.

In order to obtain an efficient service when contacting technical support, please have the following information on hand:

- a. Model number of the system, Indoor and Outdoor. If there has been any recent repairs or changes made these details may give insight to a particular problem.
- b. Try to have a good idea what the system in question can and cannot do. It's no use saying the system doesn't work when in fact one mode operates and the other doesn't.
- c. Check time clock controls haven't timed out causing the system to, correctly stop. Re-synchronising a time clock may save many a call.
- d. Where possible, be with the equipment, this will allow for any test's to be carried out and the results shared with technical support.
- e. A record of the fault codes produced by the system.

RAS Fault codes are obtained via the LED lights located on the front of the indoor unit.

RAV Fault codes are obtained via the remote controller display, [Press the "CHECK" button for 2 – 4 seconds]

On R22 and R407C COOLING ONLY equipment, the first four figures displayed after the time are the compressor start count, (NOT FAULT CODES), fault codes will automatically be displayed after the compressor start count.

The first two digits are the unit number, the third and fourth digits are the FAULT CODE, two fault codes per connected unit can be stored and displayed.

On R407C HEAT PUMP systems, the middle section of the display being the unit number, the first and second digits, displayed in the bottom section of the display are the FAULT CODES

In the event that NO fault codes are displayed, [Press the "CHECK Button followed by the FILTER Button, keeping the FILTER button depressed until the display changes] the display will read R **, the last two digits being the LAST fault the system suffered from.

RAV SM / SP [Digital Inverter R410A], fault codes are displayed automatically, in the event that there are no fault codes displayed [Press the "Spanner Button and the SET button", together for 4 seconds], the LATEST fault codes will be displayed, to scroll through the, "Second, Third and Fourth error codes, [Press "TEMP SET" up or down arrows]

On RAV-SM / SP units with infrared remote controllers, record the LED display on the indoor unit.

On MAR F Product (VRF), With the Power supply ON, set the TWO rotary switches on the large interface PCB to [TWO on the first and ZERO on the second], record the error codes from the LED display.

On MAR C/M Products (VRF), with the power supply ON, set the rotary switch to 3 and record which of the LED's are illuminated.

ON MM / SMMS / SHRM (Modular Multi / Super Modular Multi and Super Heat Recovery Module VRF), with the power supply switched ON, set the THREE rotary switches to ONE – ONE – ONE, and record the error codes from the LED display.

- f. Confirm power supply to equipment is correct, i.e. 230 volts / 400 volt
- g. Armed with the above information contact technical support on: -

0870 843 0333 [24 hours / 7 days]

Notes

Notes

Notes

Toshiba products are supplied by:

24 Hour Technical Helpline: 0870 843 0333

TOSHIBA Carrier UK Limited
Guildford Road
Leatherhead
Surrey, KT22 9UT