

TOSHIBA INSTALLATION MANUAL

Digital Inverter Air Conditioner “1 : 1 Model” Connection Interface

Use for Indoor Unit Only
MODEL : TCB-PCNT30TLE2

[For Installation Professionals]

- Before installation work, please read this manual thoroughly and install the products correctly.

CAUTIONS for SAFETY

WARNING

- **Ask an authorized dealer or qualified installation professional to install/maintain the air conditioner.**
Inappropriate installation may result in water leakage, electric shock or fire.
- **Perform installation work surely based on this Installation Manual.**
Incomplete installation causes an electric shock or a fire.
- **Ask an authorized dealer or qualified installation professional to reinstall adapters.**
Incomplete installation causes an electric shock or a fire.
- **For an electric work, this Installation Manual shall be referred and exclusive circuit shall be necessarily used. The used voltage shall be also match with the rated voltage of the product.**
If there is capacity shortage of electric circuit or installation work is poor, an electric shock or a fire may be caused.

CAUTION

- Using the specified wires, surely connect wires so that external force of wire is not applied to connecting part of the terminals; otherwise disconnection, heating or fire will generate.
- For wiring work, use wires with correct current capacity; otherwise leakage, heating or fire will generate.
- Do not apply an excessive force on the board body, otherwise bending, separation, or disconnection generates resulted in heating or fire.

- After installation work, execute a test run to confirm there is no trouble.
And also ask the customers to keep this Manual by themselves.

■ Components

Name	Q'ty	Application
P.C. board	1	1 : 1 model connection interface board
U3, U4 terminal block	1	2P terminal block for relay (U3, U4)
Relay wire (A)	1	For connection of “1 : 1 Model” Connection Interface board with U3, U4 relay terminal block (Blue connector)
Relay wire (B)	1	For connection of “1 : 1 Model” Connection Interface board with indoor control board (Red connector)
Installation Manual	1	This manual
Spacer (A)	3	For fixing “1 : 1 Model” Connection Interface board (Used when installing P.C. board on sheet metal of the electric parts box of indoor unit)
Spacer (B)	1	For fixing “1 : 1 Model” Connection Interface board (Required according to shape of indoor unit)
Screws to fix terminal block	2	For fixing relay terminal block (M4 × 14ℓ)
Bundling band	3	Used to process wires
Terminal nameplate	1	To be adhered near the relay terminal block

Before Installation

This adapter corresponds to the digital inverter air conditioner.

Do not use or connect this adapter for other type of air conditioner than the above because the indoor P.C. boards of other air conditioners differ from one of the digital inverter air conditioner.

Wiring Connection

1. Wiring connection

Remarks

- Point 1)** When controlling the digital inverter air conditioner collectively, "1 : 1 Model" Connection Interface (This option) is required.
- Point 2)** In group control or twin system, this adapter must be connected to Header unit of the indoor unit. (Connection to follower unit is unavailable.)
- Point 3)** Connect the central control devices to wires of the central control system.
- Point 4)** When controlling the digital inverter air conditioner collectively, turn on Bit 1 of SW01 in the line with the least line address No. (OFF has been set up at shipment from the factory.)

For the digital inverter air conditioner, re-setup of the address from the wired remote controller is required after automatic addressing.

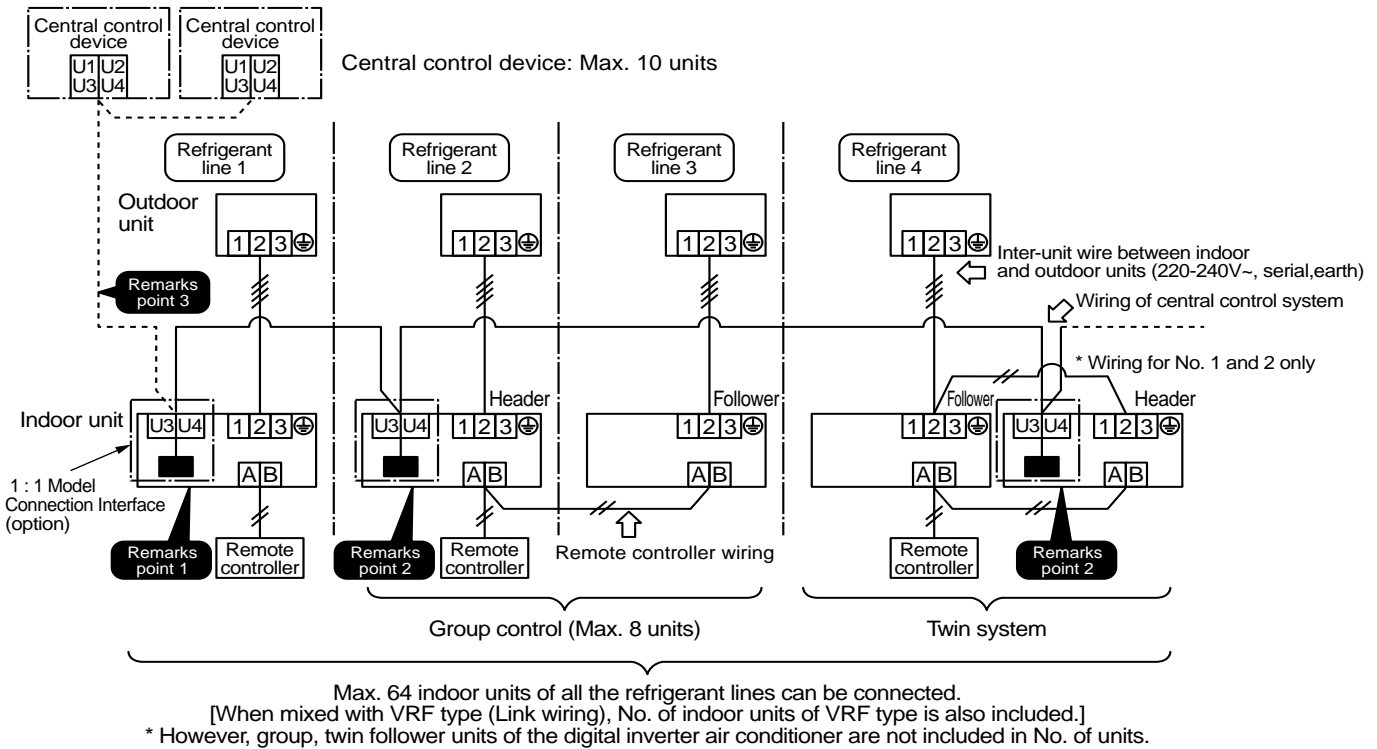

VRF : Variable Refrigerant Flow

2. Wire Specifications

No. of wires	Size	Specifications
2	Up to 1000m, braided wire 1.25mm ²	2-core shield wire
	Up to 2000m, braided wire 2.0mm ²	

- Wire is 2-core and non-polarity.
- The length is same to wire length of the central control system.
In case of system mixed with VRF type, the length includes all length of control wiring between indoor unit and outdoor units at VRFside.
- To prevent noise defect, use 2-core shield wire.
- Connect shield wires with closed-terminal connection and apply open process (insulation process) to the last termination. For grounding (earth), perform grounding with one point at indoor unit side. (During central control for digital inverter air conditioner only)

Remarks

- Point 1)** Closed terminal connection of shield wire (Connection of connecting parts of each indoor unit)
- Point 2)** Apply open process (insulation process) to the last termination.
- Point 3)** For grounding (earth), perform grounding with one point at indoor unit side.

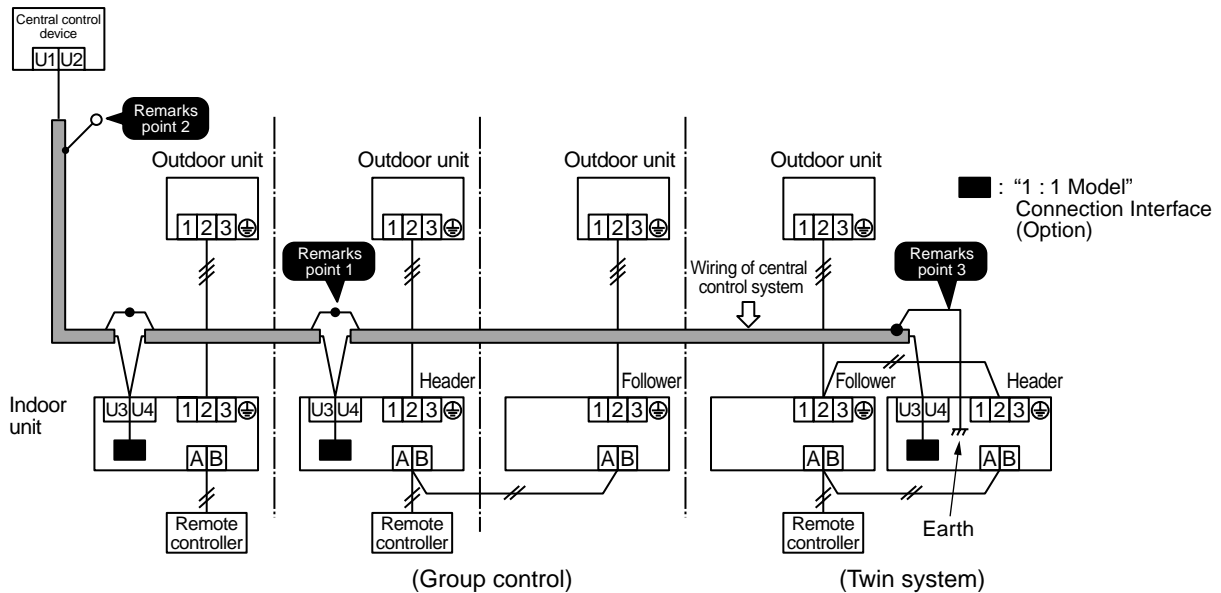

3. Wiring Diagram with Indoor Control P.C. Board

For details, refer to installation procedure for each model.

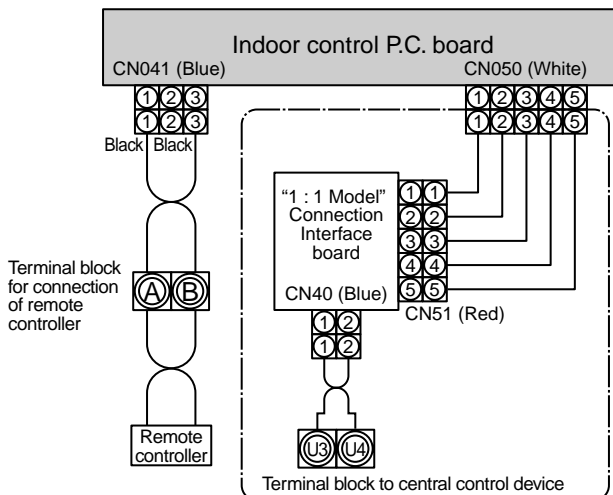

- Parts encircled with chain line are accessories attached to this product.
- indicates control P.C. board, and ⊕ indicates terminal block (Characters inside of ⊕ mark indicate terminal number.)
- There is no polarity for wire connection to terminal blocks U3 and U4.

(NOTE)

Do not apply voltage to terminals U3 and U4.

If applying voltage to U3 or U4 terminal by mistake, fusing occurs to protect terminals.

After checking wires, exchange connection of connecting connector on "1 : 1 Model" Connection Interface board from CN40 (Blue) to the spare CN44 (Brown).

Setup of P.C. Board Switch

When the units controlled collectively are all digital inverter air conditioners, it is required to set up the terminator resistor. (Collective control for units without VRF type air conditioner)

- Using SW01, set up the terminator resistor.
- **Set up the terminator resistor to only adapter connected to the indoor unit in the line with the least line address No.**

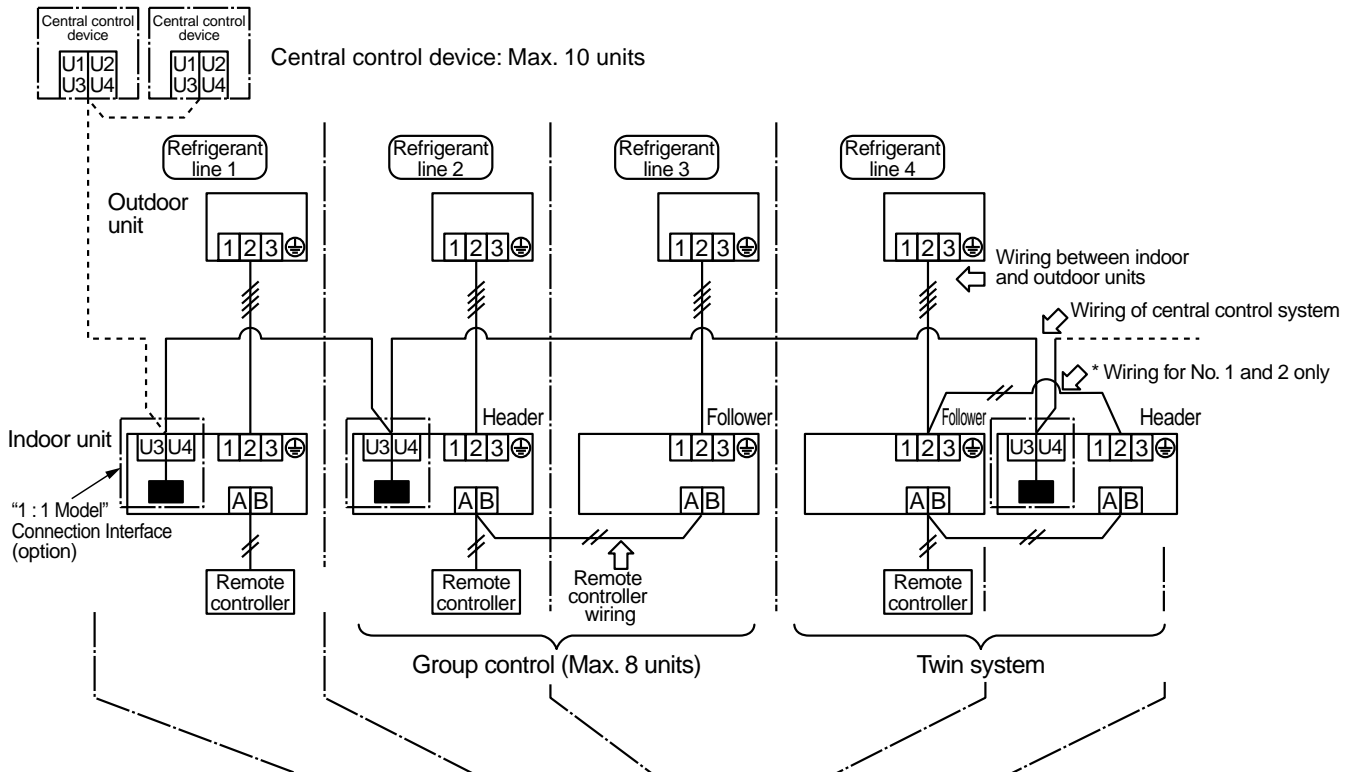

Line address	1	2	4	
SW01 bit 1	ON	OFF	OFF	(OFF when shipped from factory)
SW01 bit 2	OFF	OFF	OFF	(OFF when shipped from factory)
Remarks	Turn on SW01 bit 1.	As status at shipment from factory	As status at shipment from factory	

(Reference) Contents of switch setup

SW01		Terminator resistor	Remarks
Bit 1	Bit 2		
OFF	OFF	None	Mixed with VRF at shipment from factory (Link wiring)
ON	OFF	100Ω	Central control by digital inverter air conditioners
OFF	ON	75Ω	Spare
ON	ON	43Ω	Spare

Installation Procedure

- For installation of “1 : 1 Model” Connection Interface board and removal of relay wire, be sure to wait for a while (approx. 1 minute) after turning off the power supplies of the air conditioner and the collective control devices. If not doing so, “1 : 1 Model” Connection Interface board may be damaged.

■ In case of 4-way Air Discharge Cassette type (RAV-SM***UT-E, RAV-SP***UT-E, RAV-SM***UT-K, RAV-SM***UT-4C)

No.	Procedure
1	Using board installing spacer (A), install “1 : 1 Model” Connection Interface board to the position of electric parts box of the indoor unit. (See the figure below.)
2	Using terminal block fixing screws, install U3, U4 terminal block to the position of electric parts box of the indoor unit. (See the figure below.) <ul style="list-style-type: none"> • When tightening the screws, be sure not to damage wires. • Adhere the attached nameplate near the relay terminal block.
3	Connect the relay wire (A) from U3, U4 terminal block to CN40 (Blue) of “1 : 1 Model” Connection Interface board. Connect the relay wire (B) from CN50 (White) on the indoor P.C. board to CN51 (Red) on “1 : 1 Model” Connection Interface board.

Details

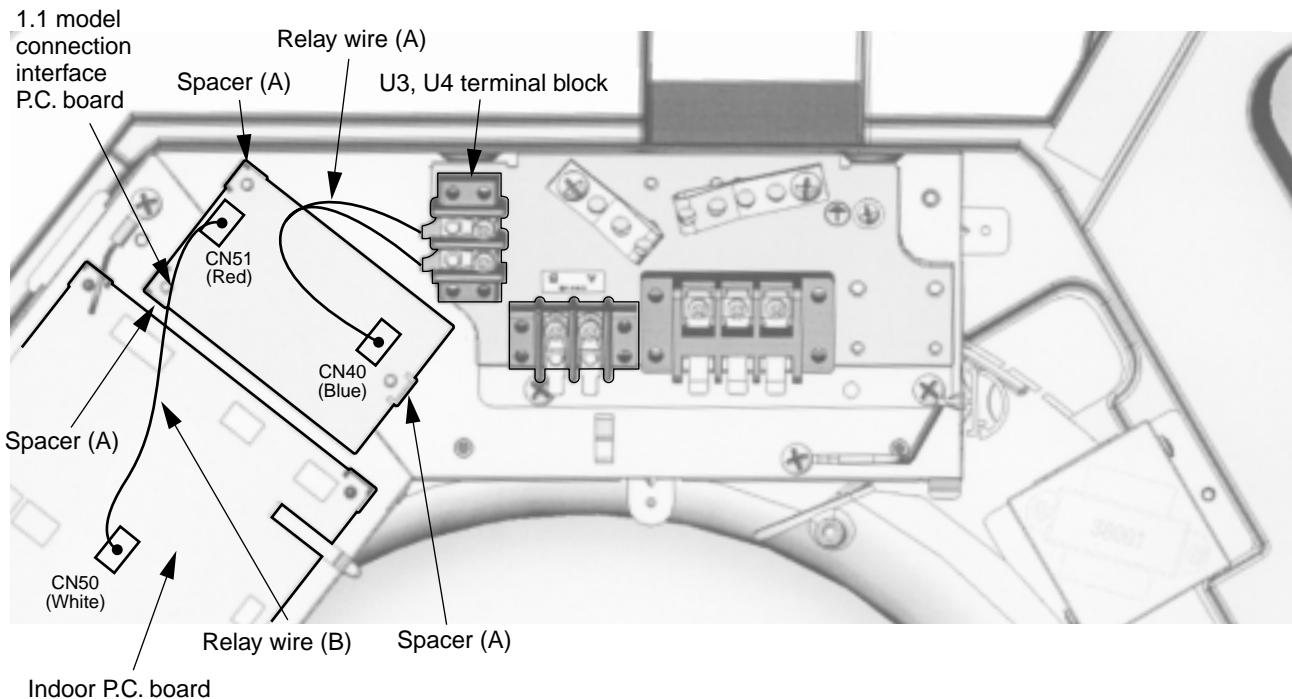

* Relay wire (A)

Connect U3, U4 terminal block with “1 : 1 Model” Connection Interface CN40 (Blue). There is no polarity for wire connection.

• Relay wire (B)

Connect CN50 (White) on indoor control P.C. board with CN51 (Red) on “1 : 1 Model” Connection Interface board.

- When installing “1 : 1 Model” Connection Interface board to electric parts box, insert three board installing spacers (A) into holes of P.C. board.

CAUTION

After connection of the relay wires (A) and (B), bind them with banding band so that wires are not caught in. In this time, be sure not to bind the relay wires (A) and (B) together with the power supply lines such as power cable, earth wire, etc.; otherwise a trouble may be caused.

■ In case of Concealed Duct type (RAV-SM**0BT-E, RAV-SM**0BT-4C)

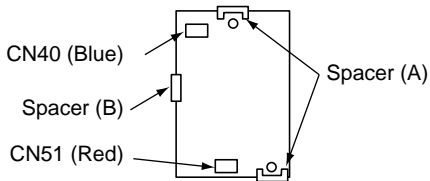
No.	Procedure
1	<p>Using board installing spacer (A), (B) install "1 : 1 Model" Connection Interface board to the position of electric parts box of the indoor unit. (See the figure below.)</p> <p style="text-align: right;"><Installation position of spacers for fixing P.C. board></p> 
2	<p>Using terminal block fixing screws, install U3, U4 terminal block to the position of electric parts box of the indoor unit. (See the figure below.)</p> <ul style="list-style-type: none"> When tightening the screws, be sure not to damage wires. Adhere the attached nameplate near the relay terminal block.
3	<p>Connect the relay wire (A) from U3, U4 relay terminal block to CN40 (Blue) of "1 : 1 Model" Connection Interface board. Connect the relay wire (B) from CN050 (White) on the indoor P.C. board to CN51 (Red) on "1 : 1 Model" Connection Interface board.</p>

Details

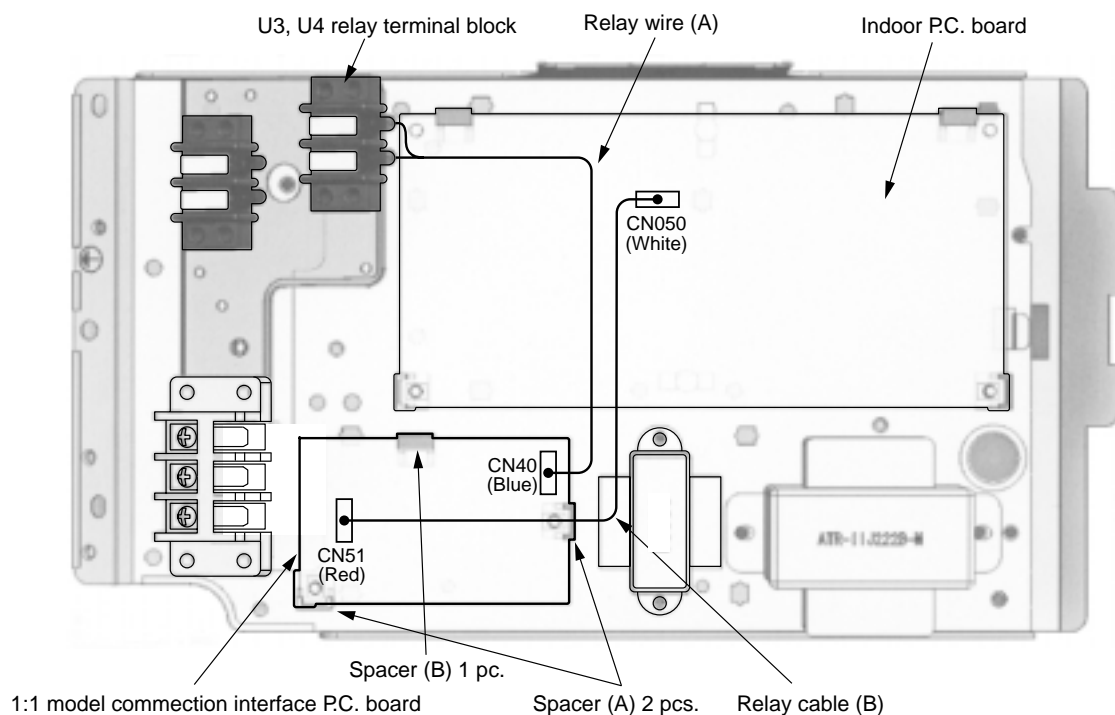

* Relay wire (A)

Connect U3, U4 terminal block with "1 : 1 Model" Connection Interface CN40 (Blue). There is no polarity for wire connection.

• Relay wire (B)

Connect CN050 (White) on indoor control P.C. board with CN51 (Red) on "1 : 1 Model" Connection Interface board.

* When installing "1 : 1 Model" Connection Interface board to electric parts box of Concealed type air conditioner, insert two board installing spacers (A) into holes of P.C. board (at upper side and lower right of P.C. board) and install one of them to the electric parts box (at lower left of P.C. board) using the board installing spacer (B) of a type which pinches the P.C. board.

CAUTION

After connection of the relay wires (A) and (B), bind them with banding band so that wires are not caught in. In this time, be sure not to bind the relay wires (A) and (B) together with the power supply lines such as power cable, earth wire, etc.; otherwise a trouble may be caused.

■ In case of Concealed Duct Standard type
(RAV-SM**2BT-E, RAV-SM**1BT-E, RAV-SM**1BT-4C)

No.	Procedure
1	Using board installing spacer (A), install "1 : 1 Model" Connection Interface board to the position of electric parts box of the indoor unit. (See the figure below.)
2	Using terminal block fixing screws, install U3, U4 terminal block to the position of electric parts box of the indoor unit. (See the figure below.) <ul style="list-style-type: none"> • When tightening the screws, be sure not to damage wires. • Adhere the attached nameplate near the relay terminal block.
3	Connect the relay wire (A) from U3, U4 terminal block to CN40 (Blue) of "1 : 1 Model" Connection Interface board. Connect the relay wire (B) from CN50 (White) on the indoor P.C. board to CN51 (Red) on "1 : 1 Model" Connection Interface board.

Details

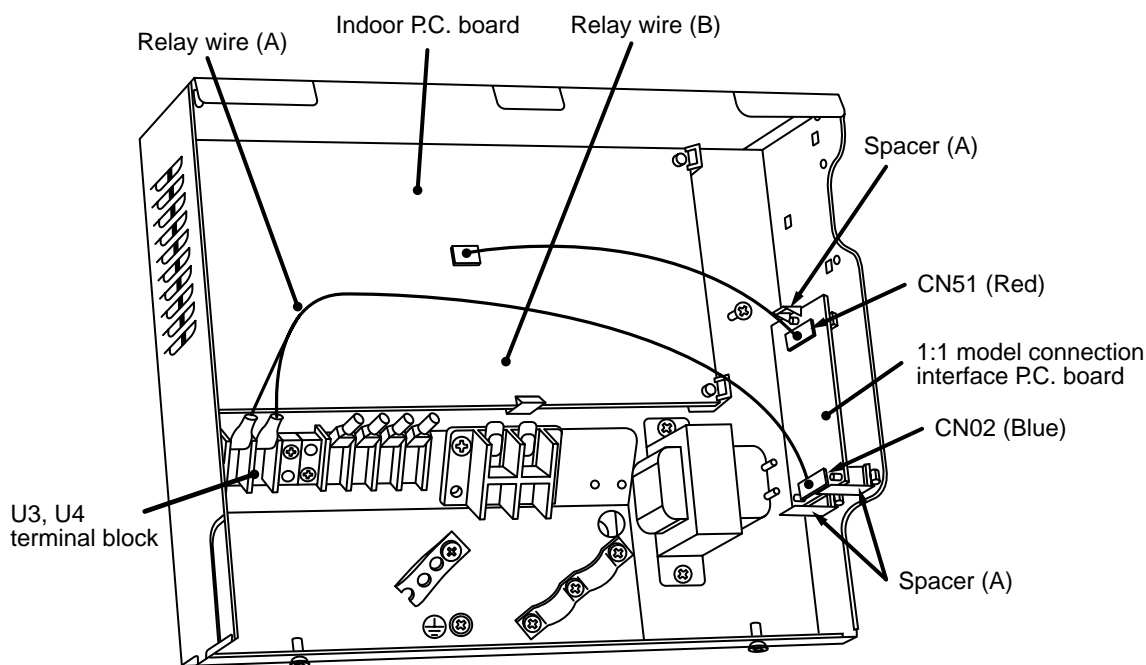

* Relay wire (A)

Connect U3, U4 terminal block with "1 : 1 Model" Connection Interface CN40 (Blue). There is no polarity for wire connection.

• Relay wire (B)

Connect CN50 (White) on indoor control P.C. board with CN51 (Red) on "1 : 1 Model" Connection Interface board.

- When installing "1 : 1 Model" Connection Interface board to electric parts box, insert three board installing spacers (A) into holes of P.C. board.

CAUTION

After connection of the relay wires (A) and (B), bind them with banding band so that wires are not caught in. In this time, be sure not to bind the relay wires (A) and (B) together with the power supply lines such as power cable, earth wire, etc.; otherwise a trouble may be caused.

■ In case of Under Ceiling type (RAV-SM***CT-E, RAV-SM***CT-4C)

No.	Procedure
1	Using board installing spacer (A), install "1 : 1 Model" Connection Interface board to the position of electric parts box of the indoor unit. (See the figure below.)
2	Using terminal block fixing screws, install U3, U4 terminal block to the position of electric parts box of the indoor unit. (See the figure below.) <ul style="list-style-type: none"> • When tightening the screws, be sure not to damage wires. • Adhere the attached nameplate near the relay terminal block.
3	Connect the relay wire (A) from U3, U4 terminal block to CN40 (Blue) of "1 : 1 Model" Connection Interface board. Connect the relay wire (B) from CN50 (White) on the indoor P.C. board to CN51 (Red) on "1 : 1 Model" Connection Interface board.

Details

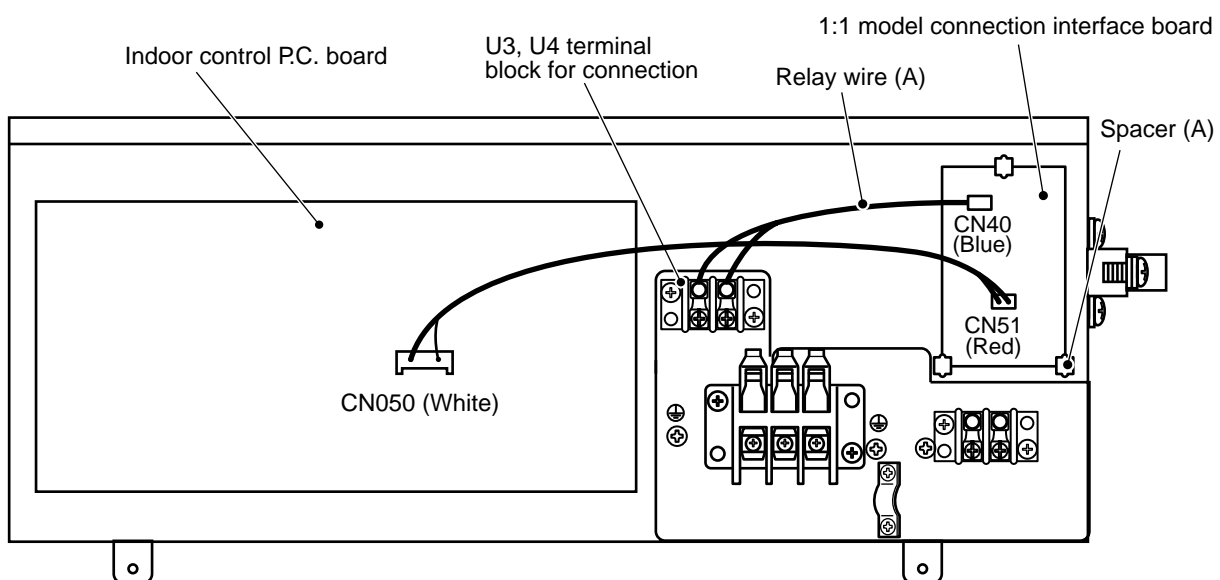

- Relay wire (A)
Connect U3, U4 terminal block with "1 : 1 Model" Connection Interface CN40 (Blue). There is no polarity for wire connection.
- Relay wire (B)
Connect CN50 (White) on indoor control P.C. board with CN51 (Red) on "1 : 1 Model" Connection Interface board.
- When installing "1 : 1 Model" Connection Interface board to electric parts box, insert three board installing spacers (A) into holes of P.C. board.

CAUTION

After connection of the relay wires (A) and (B), bind them with banding band so that wires are not caught in. In this time, be sure not to bind the relay wires (A) and (B) together with the power supply lines such as power cable, earth wire, etc.; otherwise a trouble may be caused.

Usage

- Refer to Owner's Manual for the central control devices (TCB-SC642TLE2, TCB-CC163TLE2)

Other Cautions

- In a group operation, be sure to turn on power supplies of all the indoor units in group control. (Within 3 minutes)
When power supply of the Header unit is not turned on, there is a possibility that the Header unit exchanges with Follower unit. (If Header unit is exchanged, the central control is unavailable.)

Address No. Setup

■ Outline

To connect the digital inverter air conditioner to TCC-LINK central control system using this interface, it is required to set up address of each connected indoor unit for central control in the following procedure.

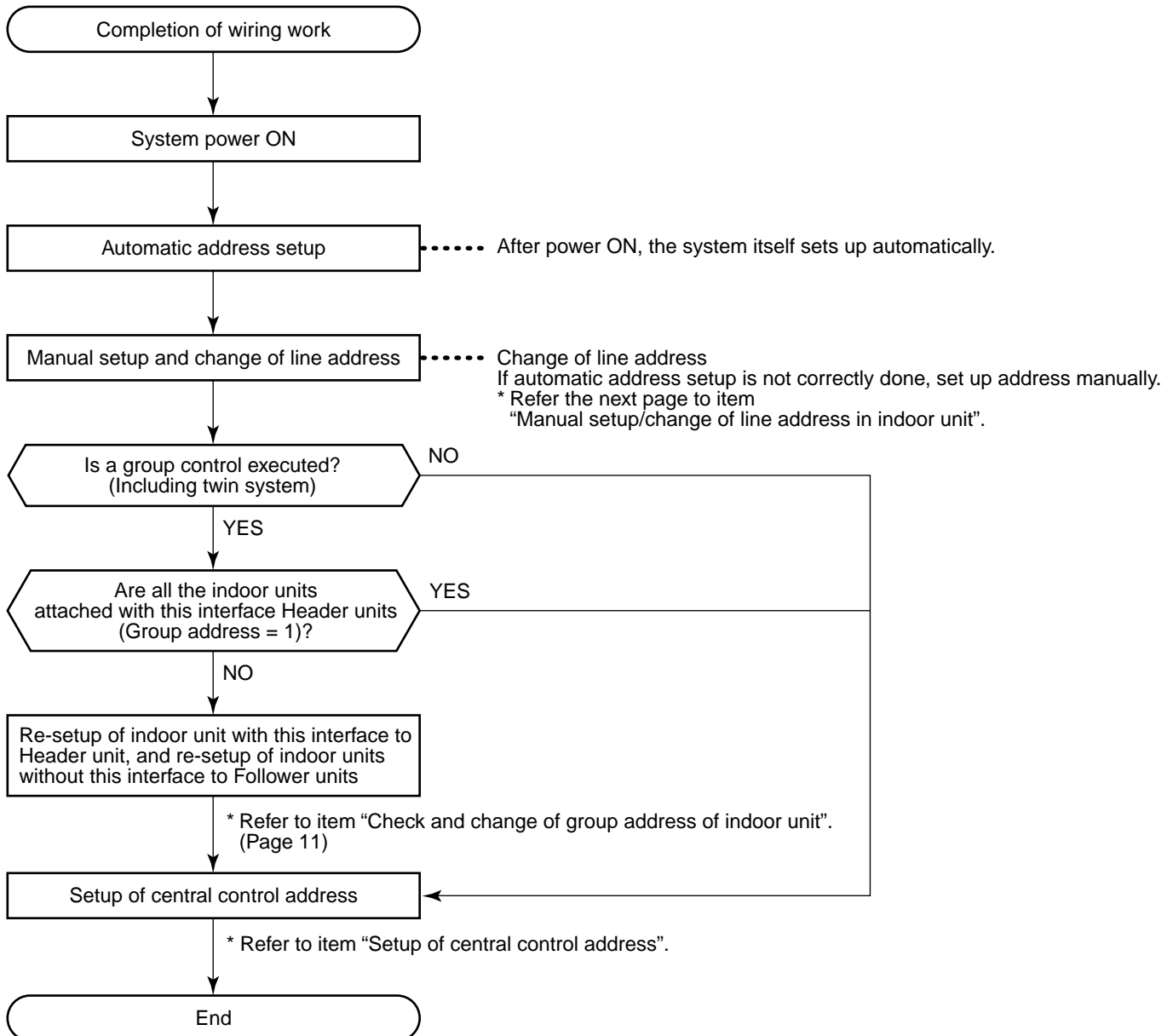

■ Manual Setup/Change of Line Address in Indoor Unit

[In case of 29 refrigerant lines or less (Includes No. of refrigerant lines at Multi side if mixed)]

After the system power supply has been turned on, all the line addresses are allocated to "1" by automatic address setup except group control. Therefore change setup of the line address using the wired remote controller for each refrigerant line.

Change line address for each refrigerant line.

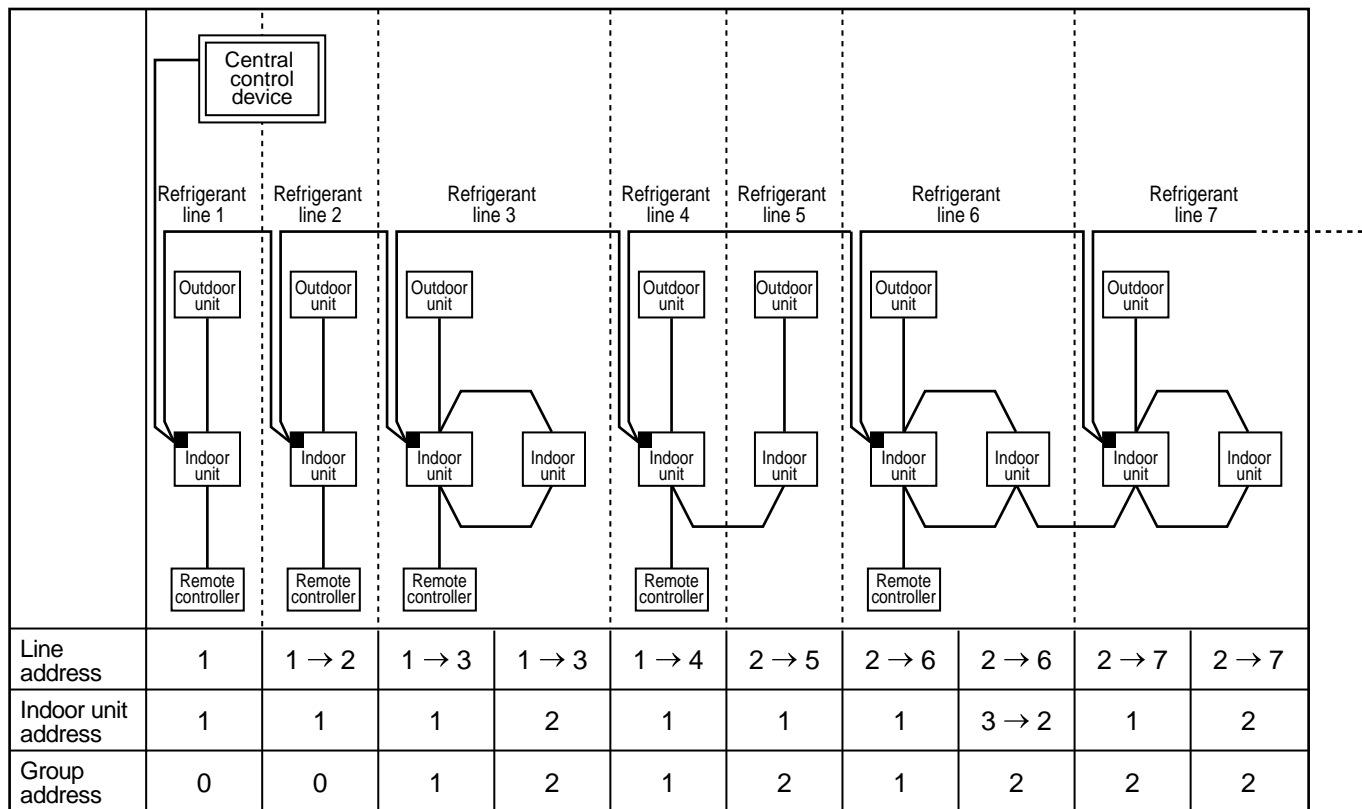

In case of group control including twin system, the automatic address does not normally work. Set the automatic address again from the wireless remote controller manually.

Line address (1)	1	2	3	3	4	5	6	6	7	7
Indoor unit address	1	1	1	2	1	1	1	2	1	2
Group address	0	0	1	2	1	2	1	2	2	2

[■ → "1 : 1 Model" connection interface]

* For change/setup method by wired remote controller, refer to "Change method of address setup". (Page 15)

* Allocating different numeral value for each refrigerant line, set up the line address so that it does not overlap with other address No. (When controlling collectively VRF type units mixed with digital inverter air conditioner unit, set up numeral value which also differs from line address at VRF type air conditioner side.)

■ Manual Setup/Change of Line Address in Indoor Unit

[In case of 30 refrigerant lines or more (Includes No. of refrigerant lines at Multi side if mixed)]

After the system power supply has been turned on, all the line addresses are allocated to "1" by automatic address setup except group control. Therefore change setup of the line address using the wired remote controller for each refrigerant line.

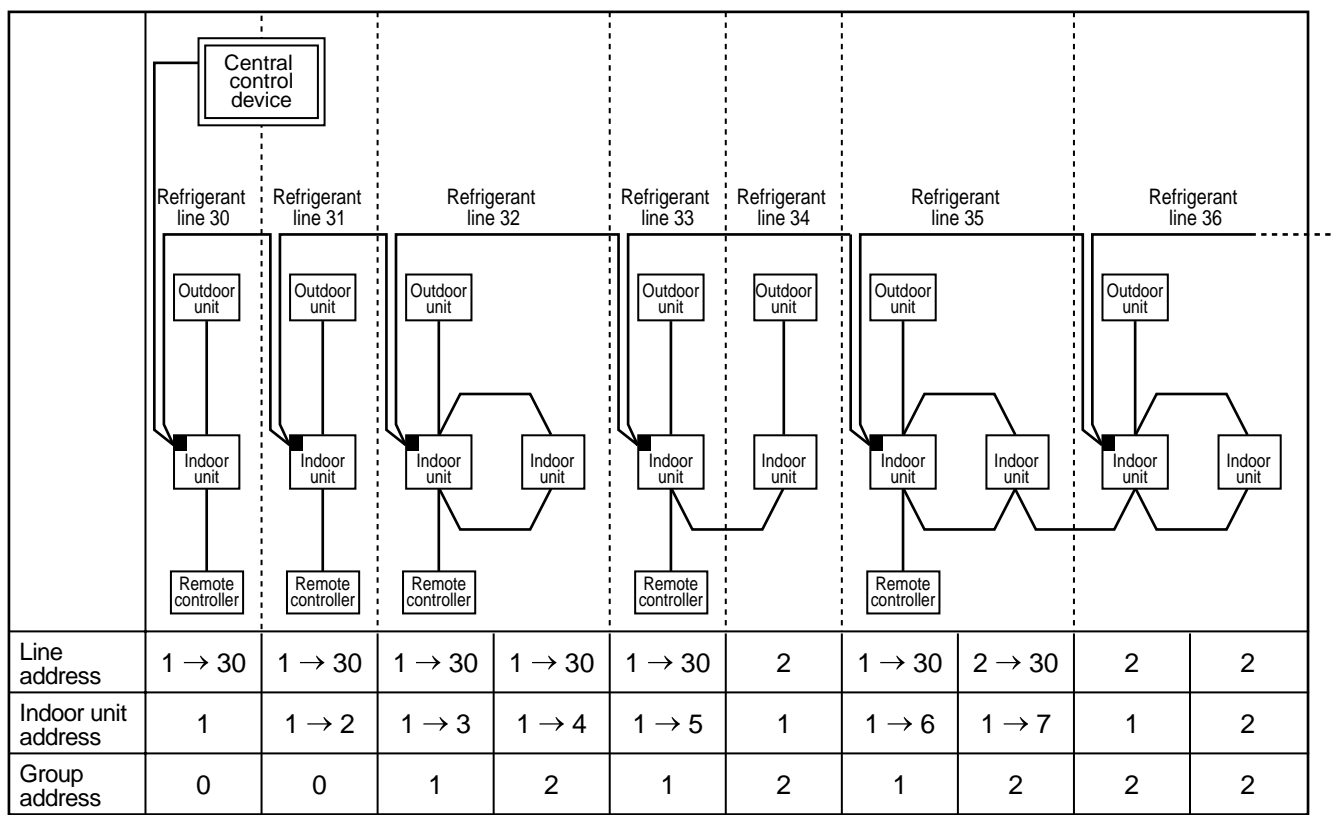

Point (1) Set "30" to all the line addresses of indoor units attached with these interface

Point (2) Change the indoor address so that the indoor unit numbers do not overlap.

Point (3) When the indoor unit attached with this interface is controlled with twin or system, change also line address of the follower unit to "30".

In case of group control including twin system, the automatic address does not normally work. Set the automatic address again from the wireless remote controller manually.

Line address (1)	30	30	30	30	30	2	30	30	2	2
Indoor unit address	1	2	3	4	5	1	6	7	1	2
Group address	0	0	1	2	1	2	1	2	2	2

[■ → "1 : 1 Model" connection interface]

* For change/setup method by wired remote controller, refer to "Change method of address setup". (Page 15)

* Allocating different numeral value for each refrigerant line, set up the line address so that it does not overlap with other address No. (When controlling collectively VRF type units mixed with digital inverter air conditioner unit, set up numeral value which also differs from line address at VRF type air conditioner side.)

■ Check and Change of Group Address of Indoor Unit

In group control or twin operation, the group address is allocated to indoor unit by automatic address setup after the system power supply has been turned on. From these addresses, "Header unit": "1" and "Follower unit": "2" can be recognized. As the central control device (remote controller) communicates with "Header unit" only, set up the group address from wired remote controller so that the indoor unit attached with the adapter becomes "Header unit".

• Check method for Header unit

Beforehand check the indoor unit attached with this interface.

During stop of the equipment.

<Procedure>

- 1 Push **SET**, **CL** and **TEST** buttons simultaneously for 4 seconds or more.

(The firstly displayed unit No. is the header indoor unit No. in the group control.)

- 2 The indoor unit of which fan was turned on is the header indoor unit.

If the header unit is not one with this interface, change it according to "How to set up Header unit".

- 3 Pushing **TEST** button returns the mode to normal mode.

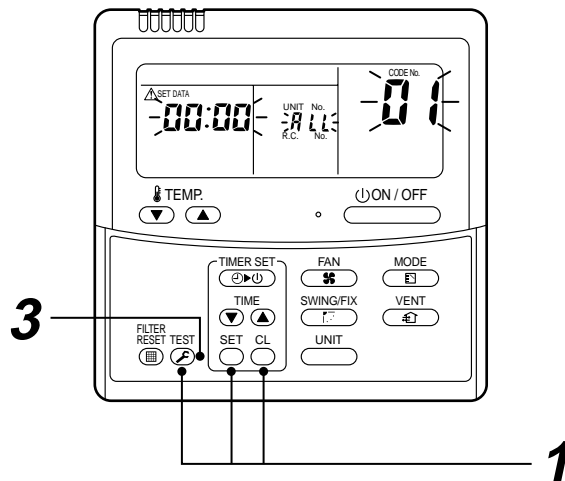

• How to set up Header unit

(In case when the indoor unit of which fan was turned on is not one attached with adapter)

Change address in the following procedure.

<Procedure>

- 1 Push **SET**, **CL** and **TEST** buttons simultaneously for 4 seconds or more.

(The firstly displayed unit No. is the header indoor unit No. in the group control.)

- 2 The indoor unit of which fan was turned on is the header indoor unit.

- 3 Using the setup temperature **▼** and **▲** buttons, select item code "14".

- 4 Check that the setup data is 0001, and then change the setup data to 0002 using the timer time **▼** and **▲** buttons.

- 5 Push **SET** button. In this time, the setup ends if display changes from flashing to lighting.



(To be continued)

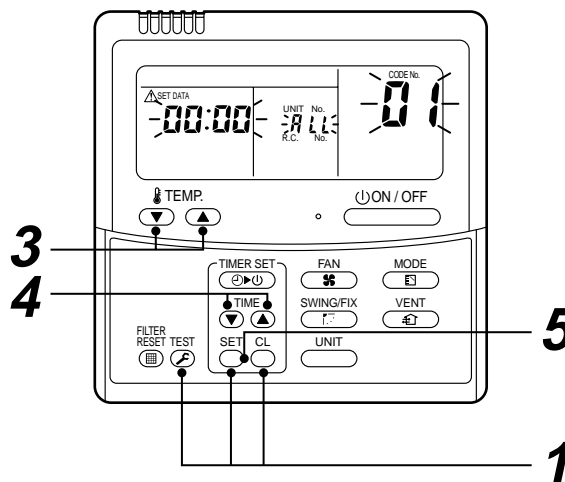



- 6** Push **UNIT** button, and then turn on fan of the indoor unit which is attached with adapter.
- 7** Leave the item code as it is. (Select item code 14.)
- 8** Check that the setup data is 0002, and then change the setup data to 0001 using the timer time **▼** and **▲** buttons.
- 9** Push **SET** button. In this time, the setup ends if display changes from flashing to lighting.
- 10** When the above setup completed, push **UNIT** button to select indoor unit of which setup was changed and then check the changed contents. (Item code 14 as it is)
* When pushing **CL** button, the setup contents can be cleared.
(In this case, repeat procedure from **1**.)

Note) Cancellation is unavailable if the item code is changed.

11 Push **TEST** button. (Setup is determined.)

When pushing **TEST** button, the display disappears and the status becomes the normal stop status. (The remote controller operation is not accepted for approx. 1 minute after pushing **TEST** button.)

* If the remote controller operation is not accepted for 1 minute or more after pushing **TEST** button, it is considered that the address setup is incorrect and the automatic address setup is being performed again. Change setup again after approx. 5 minutes.

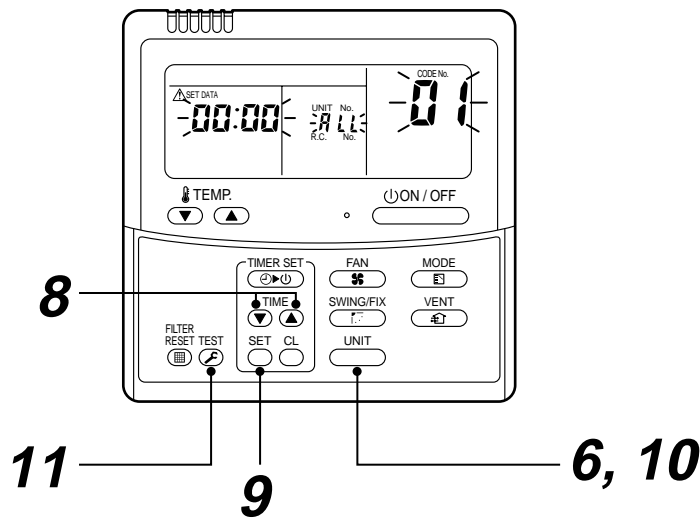

■ Setup of Central Control Address

* For details, refer to Installation Manual for central remote controller.

1. Address setup method is classified into the following three methods.
 - 1) Manual setup from wired remote controller
 - 2) Manual setup from central remote controller
 - 3) Automatic setup from central remote controller
2. In group control, set up the central control address to the Header unit of the group.

Determination of indoor address

Is automatic address set up?

Automatic setup

Manual setup

Setup from wired remote controller

Setup from central remote controller

Manual address setup from wired remote controller

- 1 Push and buttons simultaneously for 4 seconds or more.
Do not push button.
- 2 Set "03" to item code with temperature setup and buttons.
- 3 Using timer setup/time and buttons, set up the central control address.
- 4 Registration completes with button. (**SETTING** changes from flashing to lighting.)
- 5 Push button.
- 6 Initial setup starts. (For approx. 1 minute)
- 7 End

Manual address setup with item code "C1" of central remote controller

- 1 Push and buttons simultaneously for 4 seconds or more.
- 2 Set "C1" to item code with temperature setup and buttons.
- 3 Push button.
- 4 Select or buttons to select zone and group to be registered.
- 5 Using and , perform registration. (Select the indoor unit.)
- 6 Registration completes with button.
- 7 Repeat procedure 4 to 6.
- 8 Push button.
- 9 **SETTING** flashes and the initial setup starts.
- 10 End

Automatic address setup with item code "C2" of central remote controller

- 1 Push and buttons simultaneously for 4 seconds or more.
- 2 Set "C2" to item code with temperature setup and buttons.
- 3 Push button and the address setup starts. "C2" goes on and **SETTING** flashes.
- 4 When **SETTING** goes off and "C2" flashes, setup ends.
- 5 Push button.
- 6 **SETTING** flashes and the initial setup starts. (For approx. 1 minute)
- 7 End

Check method

Check overlap of central control addresses

Make operation status by pushing buttons of central remote controller three times each.

When there is overlapped units

An alarm code "L20" is displayed on the remote controller and alarm code "L20" or "P30" on central remote controller, respectively.

[Wired remote controller:
Displayed immediately
central remote controller:
After 4 minutes at maximum]

Overlapped
YES

Overlapped?

No overlap

End

(Example)

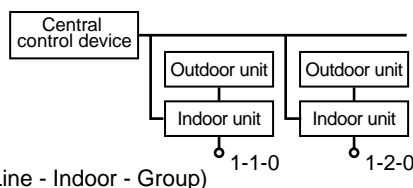

(Line - Indoor - Group)

*1
In case of digital inverter air conditioner, if the same line address is set up to the multiple indoor units which are controlled collectively, the central control address setup is impossible by this method.

<Central control address/zone/group correspondence table>

Central control Address	Zone	Group	Central control Address	Zone	Group	Central control Address	Zone	Group	Central control Address	Zone	Group
1	1	1	17	2	1	33	3	1	49	4	1
2	1	2	18	2	2	34	3	2	50	4	2
3	1	3	19	2	3	35	3	3	51	4	3
4	1	4	20	2	4	36	3	4	52	4	4
5	1	5	21	2	5	37	3	5	53	4	5
6	1	6	22	2	6	38	3	6	54	4	6
7	1	7	23	2	7	39	3	7	55	4	7
8	1	8	24	2	8	40	3	8	56	4	8
9	1	9	25	2	9	41	3	9	57	4	9
10	1	10	26	2	10	42	3	10	58	4	10
11	1	11	27	2	11	43	3	11	59	4	11
12	1	12	28	2	12	44	3	12	60	4	12
13	1	13	29	2	13	45	3	13	61	4	13
14	1	14	30	2	14	46	3	14	62	4	14
15	1	15	31	2	15	47	3	15	63	4	15
16	1	16	32	2	16	48	3	16	64	4	16
									99	Not set up	

■ Address Setup/Change Method

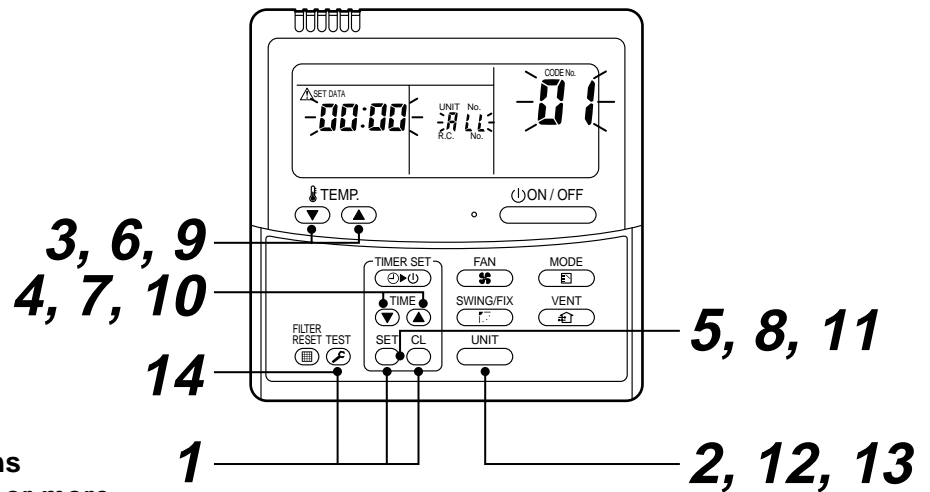

<Procedure>

1 Push **SET**, **CL** and **TEST** buttons simultaneously for 4 seconds or more.

LCD changes to flashing.

(The firstly displayed unit No. is the header indoor unit No. in the group control.)

2 In group control, use **UNIT** button for change.

Select the indoor unit No. (The fan of the selected indoor unit is turned on.)

<Line address>

3 Using the setup temperature **▼** and **▲** buttons, select item code "12".

4 Using timer time **▼** and **▲** buttons, set up the line address.

5 Push **SET** button. (OK when display goes on.)

<Indoor unit address>

6 Using the setup temperature **▼** and **▲** buttons, select item code "13".

7 Using timer time **▼** and **▲** buttons, set up the indoor unit address.

8 Push **SET** button. (OK when display goes on.)

<Group address>

9 Using the setup temperature **▼** and **▲** buttons, select item code "14".

10 Using timer time **▼** and **▲** buttons, set up Individual = 0000, Header unit = 0001, and Follower unit = 0002.

11 Push **SET** button. (OK when display goes on.)

12 Using **UNIT** button, select an indoor unit No. to be changed at the next time.
Repeat procedure from **3** to **12** and change setup so that addresses are not overlapped.

13 After the above change, push **UNIT** button to check the changed contents.

14 If all is right, push **TEST** button. Setup ends.

<Wiring example of 2 lines>

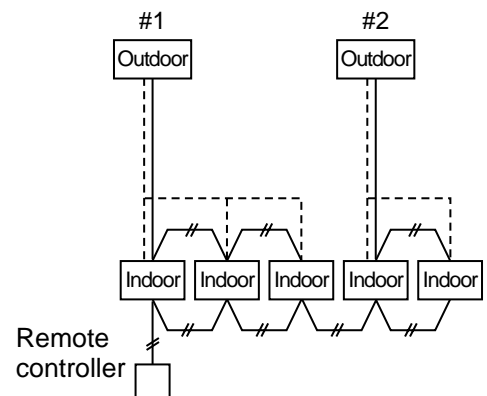

Line address	→ 1	1	1	2	2
Indoor unit address	→ 1	2	3	1	2
Group address	→ 1	2	2	2	2
		Header unit		Follower unit	

Group address	
Individual	: 0000
Header unit	: 0001
Follower unit	: 0002
} In case of group control	

Alarm code when addresses are overlapped

	Procedure	Alarm code
Case 1	<p>When line addresses are overlapped</p> <div style="display: flex; justify-content: space-around; margin-top: 10px;"> <div style="border: 1px solid black; padding: 5px; width: 45%;"> <p>Line address : 1 Indoor address : 1 Group address : 0</p> <p>Central control address : 1</p> </div> <div style="border: 1px solid black; padding: 5px; width: 45%;"> <p>Line address : 1 Indoor address : 1 Group address : 0</p> <p>Central control address : 2</p> </div> </div>	<p>Wired remote controller side Line 1: E08 Line 2: E08</p> <p>Central remote controller side E08 to Line 1 or Line 2</p>
Case 2	<p>When line addresses are overlapped (Both Line 1 and 2 operate)</p> <div style="display: flex; justify-content: space-around; margin-top: 10px;"> <div style="border: 1px solid black; padding: 5px; width: 45%;"> <p>Line address : 1 Indoor address : 1 Group address : 0</p> <p>Central control address : 1</p> </div> <div style="border: 1px solid black; padding: 5px; width: 45%;"> <p>Line address : 2 Indoor address : 1 Group address : 0</p> <p>Central control address : 1</p> </div> </div>	<p>Wired remote controller side Line 1: L20 Line 2: L20</p> <p>Central remote controller side L20 to Line 1 or Line 2</p>
Case 3	<p>When only one-side Line 2 operates from remote controller, and overlap of the central control address is detected in Case 2</p> <ul style="list-style-type: none"> Line 1: During stop Line 2: Under operation (Overlap of central control address is detected.) <div style="border: 1px solid black; padding: 10px; margin-top: 20px; width: fit-content; margin-left: auto; margin-right: auto;"> <p>Line 1: Alarm code is output even if it stops. Line 2: Alarm code is not output to the central side. (Alarm is displayed on the wired remote controller.)</p> </div>	<p>Wired remote controller side Line 1: No alarm Line 2: L20</p> <p>Central remote controller side Line 1: No alarm Line 2: L20</p> <p style="text-align: center;">or</p> <div style="border: 1px solid black; padding: 5px; width: fit-content; margin-left: auto; margin-right: auto;"> <p>Line 1: P30 Line 2: No alarm</p> </div>